

# Dual Modular Safety Shutoff Valves

**DMV-D 525/11**  
**DMV-DLE 525/11**

**DUNGS**<sup>®</sup>  
Combustion Controls



**Two normally closed safety shutoff valves in one housing; each with the following approvals.**

#### CSA Certified

- ANSI Z21.21 • CSA 6.5
- Marked C/I
- File # 157406

#### FM Approved

- Class 7411
- File # 3005931

#### EU Gas Appliance Directive

- EN161
- CE-0085AO0237

#### Commonwealth of Massachusetts Approved Product

- Approval code G1-1107-35
- Gas Safety Shutoff Valve

#### US, Canadian and EU Models

- DMV-D 525/11
- DMV-DLE 525/11
- 2 in. NPT
- Rp2

#### Codes and Standards:

This product is intended for installations covered by but not limited to NFPA 86, ANSI Z83.4, ANSI Z83.18, ANSI Z21.13, or CSA B149.3.

**DUNGS is an ISO 9001 manufacturing facility.**

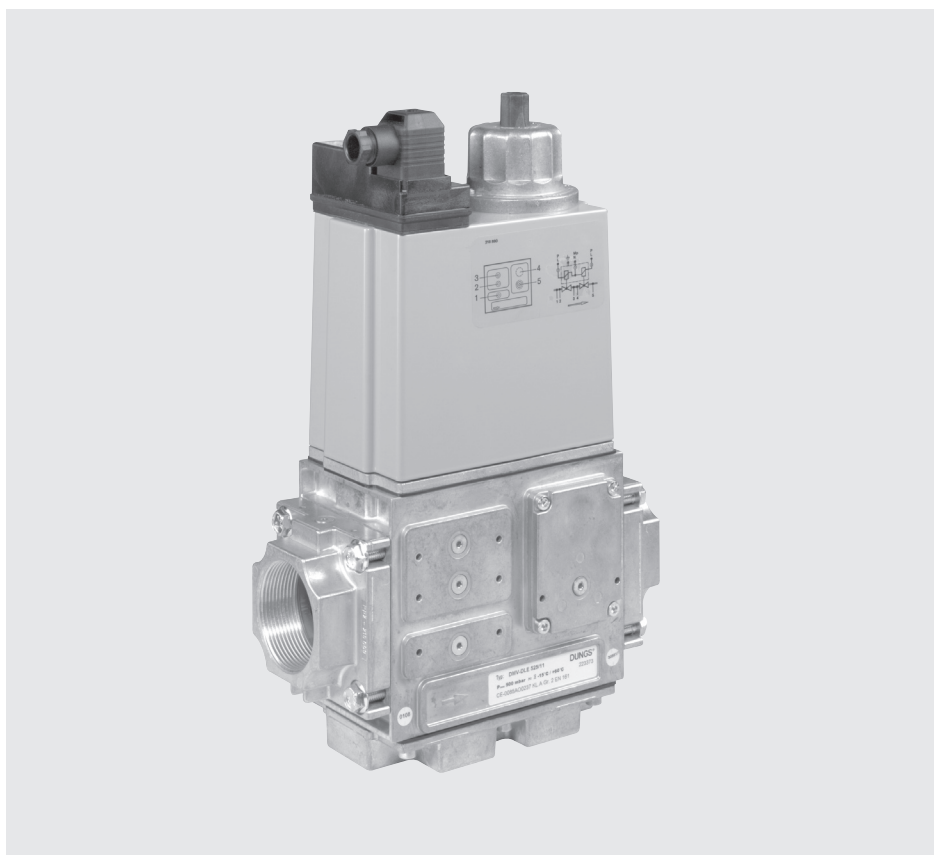

#### Description

The Dual Modular Valve (DMV) combines two safety shutoff valves in one compact housing, which can be wired independently or in parallel.

Valve 1 (V1) of the DMV-D and DMV-DLE series is fast opening and fast closing. Valve 2 (V2) of the DMV-D is fast opening, while V2 of the DMV-DLE is slow-opening for smoother light-off. Max. flow adjustment on V2 provides variable main flow on both models.

Internal profiles and compact design optimize flow and provide a low pressure drop.

Directly mounting the following accessories creates a compact valve train without additional piping:

- High and low gas pressure switches
- Valve proving system
- DMK Butterfly control valve

#### Application

The DMV is recommended for industrial and commercial heating applications that require two safety shutoff valves. The DMV is suitable for natural gas, propane, butane, air and inert gases. Suitable for up to 0.1% by volume, dry H<sub>2</sub>S.

**DMV-D 525/11** Two normally closed safety shutoff valves in one housing. V1 and V2 are fast opening, fast closing. Adjustable max. flow with V2.

**DMV-DLE 525/11** Two normally closed safety shutoff valves in one housing. V1 fast opening, fast closing. V2 is slow opening, fast closing. Adjustable max. flow and adjustable initial lift with V2.

## Specifications

Body sizes pipe size / thread	DMV-D(LE) 525/11 2" NPT or Rp	
Max. operating pressure	7 PSI (500 mbar) FM, CE (Class A)	5 PSI (360 mbar) CSA
Max. body pressure	15 PSI (1000 mbar)	
Max. close-off pressure	7 PSI (500 mbar) FM, CE (Class A)	5 PSI (360 mbar) CSA
Electrical ratings (+10% / -15%)	110 - 120 Vac /50 - 60 Hz 24 Vac /50 - 60 Hz	220 - 240 Vac /50 - 60 Hz 24 Vdc
Power ratings	DMV-D(LE) 525/11: 110 VA <small>Ratings shown are total power consumption for both valves inclusive. Inrush and full load current have the same VA rating.</small>	
Enclosure rating	NEMA Type 12	
Electrical connection	DIN-connector with 1/2" NPT conduit adapter	
Operating time	100 % duty cycle	
Closing time	< 1 s	
Opening time (to max. flow)	DMV-D 525/11 DMV-DLE 525/11	V1 & V2 < 1 s V1 < 1 s; V2 Adjustable to approx. 10 to 20 s at 70 °F
Initial lift adjustment	Adjustable on V2	DLE only; 0 to 70 % of total flow; 0 to 35% of stroke
Max. flow adjustment	Adjustable on V2	<10 to 100 % of total flow; <10 to 100% of stroke
Materials in contact with gas	Housing: Aluminum, Steel; free of nonferrous metals. Sealings on valve seats: NBR-based rubber	
Ambient temperature rating	+5 °F to +140 °F (-15 °C to +60 °C)	
Installation position	Safety valve upright vertical to horizontal	
Test ports Pressure switch mounting ports	G 1/8 ISO 228 ports available on both sides. Each side has two ports upstream of V1, two between V1 and V2, one downstream V2, and one on each flange.	
Gas strainer (standard)	Installed in the housing upstream V1 (23 mesh)	
Position indication (order separately)	CPI 400 with indication lamps and SPDT interlock switch or Visual indicator (VI)	
Valve proving system	Requires VPS 504; mounts directly to either side of DMV	

## DMV dual modular safety shutoff valve system

Optional mounting system shown,  
other configurations possible

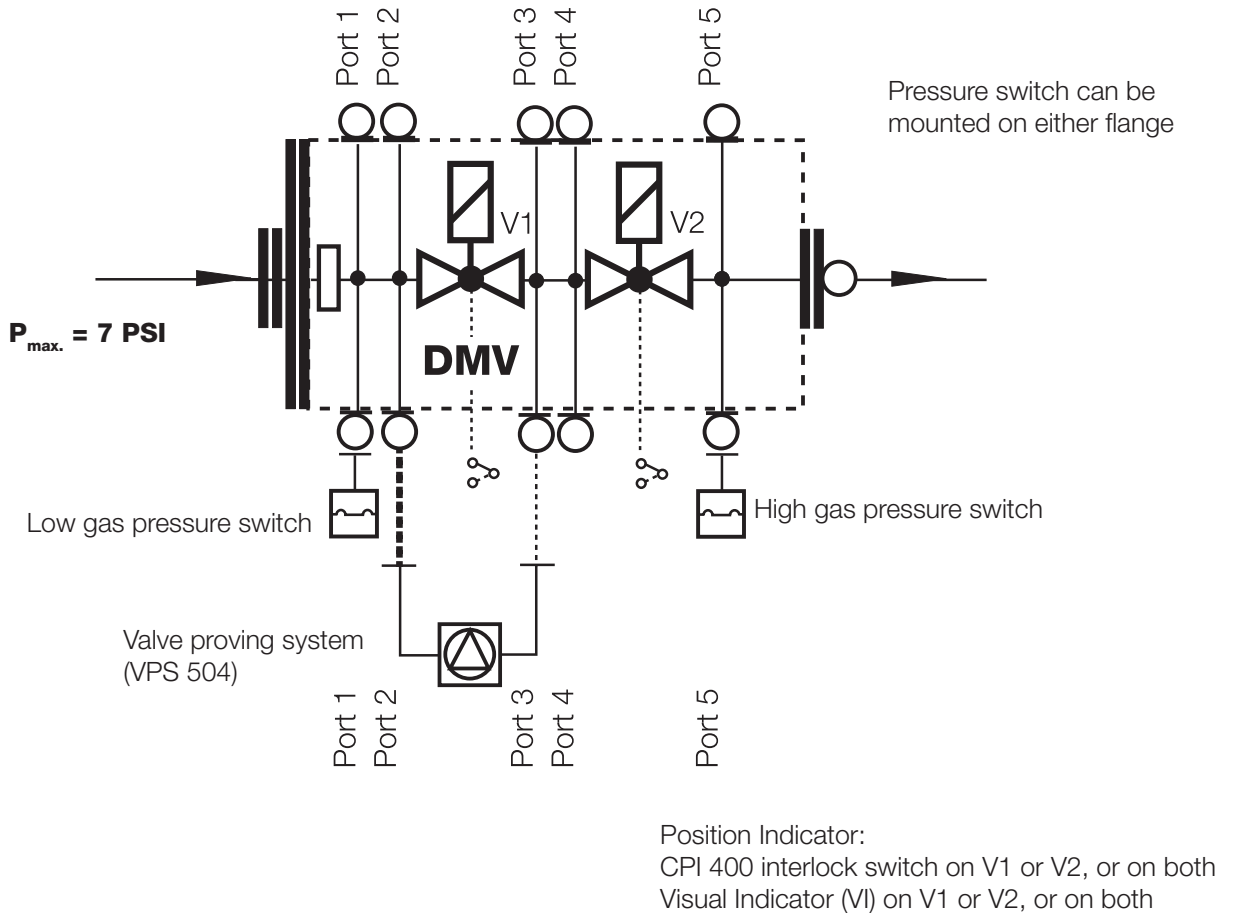

**!** When an accessory is added to the DMV, it may not be possible to mount other devices.

### Additional Accessories

#### VPS 504

Valve proving system (approved by some authorities having jurisdiction in lieu of vent valve and “proof of closure” e.g. FM, IRI).

#### GAO/GMH/GML A2 pressure switch

#### Position indication

CPI 400 with indication lamps and SPDT interlock switch, or Visual indicator (VI)

#### DMK butterfly control valve

Mounts directly downstream of DMV to modulate gas flow. Requires actuator. Use DMA actuator with DMK butterfly valve.

#### Adapters

- 1/4" NPT adapter (225-047)
- 1/2" NPT Pilot gas adapter; Check flow requirements. (225-043)
- G 1/8" Test nipple (219-008)

**Dimensions inch (mm)**

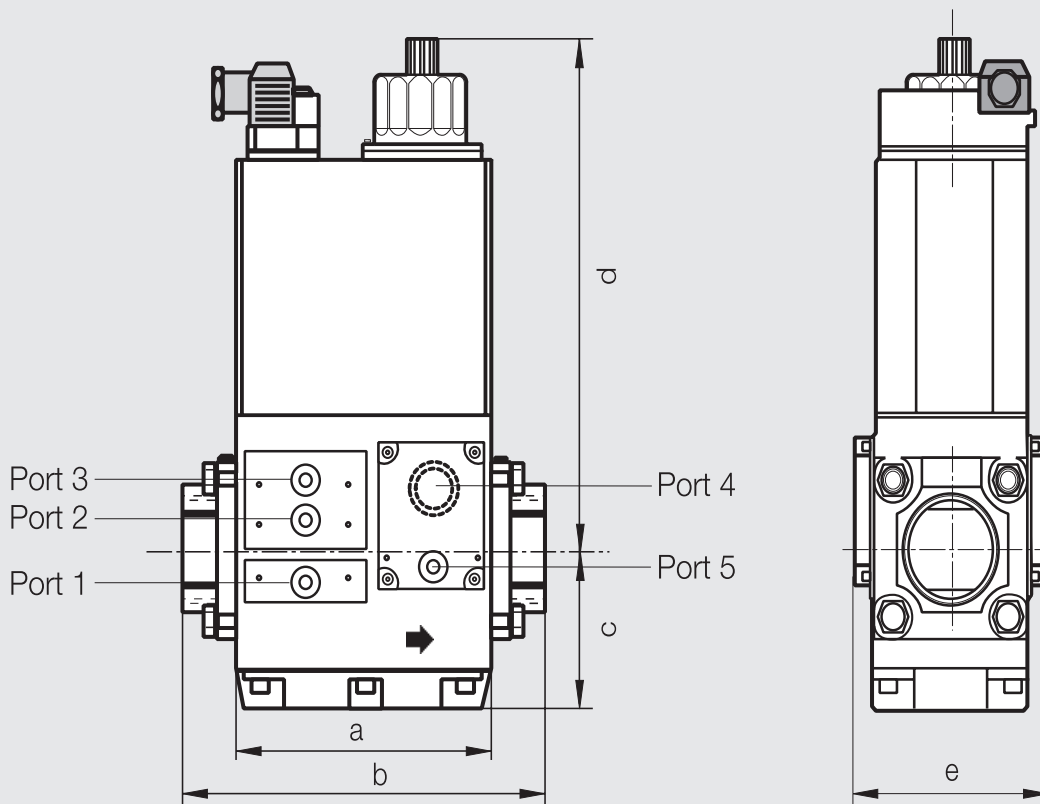

Type	110-120 VAC 50-60 Hz Order No.	220-240 VAC 50-60 Hz Order No.	24VDC Order No.	Power* [VA]	Dimensions [inch] Dimensions [mm]					Weight [lbs] [kg]
					a	b	c	d	e	
<b>DMV-D 525/11</b>	223-368	223-367	223-370	110	<b>6.4</b> 162	<b>9.4</b> 239	<b>3.5</b> 88	<b>9.7</b> 245	<b>4.8</b> 123	<b>26.6</b> 12.1
<b>DMV-DLE 525/11</b>	223-374	223-373	223-376	110	<b>6.4</b> 162	<b>9.4</b> 239	<b>3.5</b> 88	<b>9.7</b> 245	<b>4.8</b> 123	<b>27.0</b> 12.3

Valve	Flange	NPT	Rp
DMV-D (LE) 525/11	2"	232-407	215-384

\* Inrush current and full load current have the same VA rating.

<b>DIN-Connector</b>	210-319
<b>CPI 400 valve switch</b>	224-253A
<b>Visual indicator</b>	211-202A

<b>Replacement Coil Part # for 120Vac</b>	<b>Replacement Coil Part # for 24Vdc</b>	<b>Replacement PCB Part # for 120Vac</b>	<b>Replacement PCB Part # for 24Vdc</b>
225-168	225-170	225-379A	225-381A

 **Please order flanges,  
DIN-Connector and position  
indicators separately**

**DMV-D(LE) 525/11**  
sectional drawing

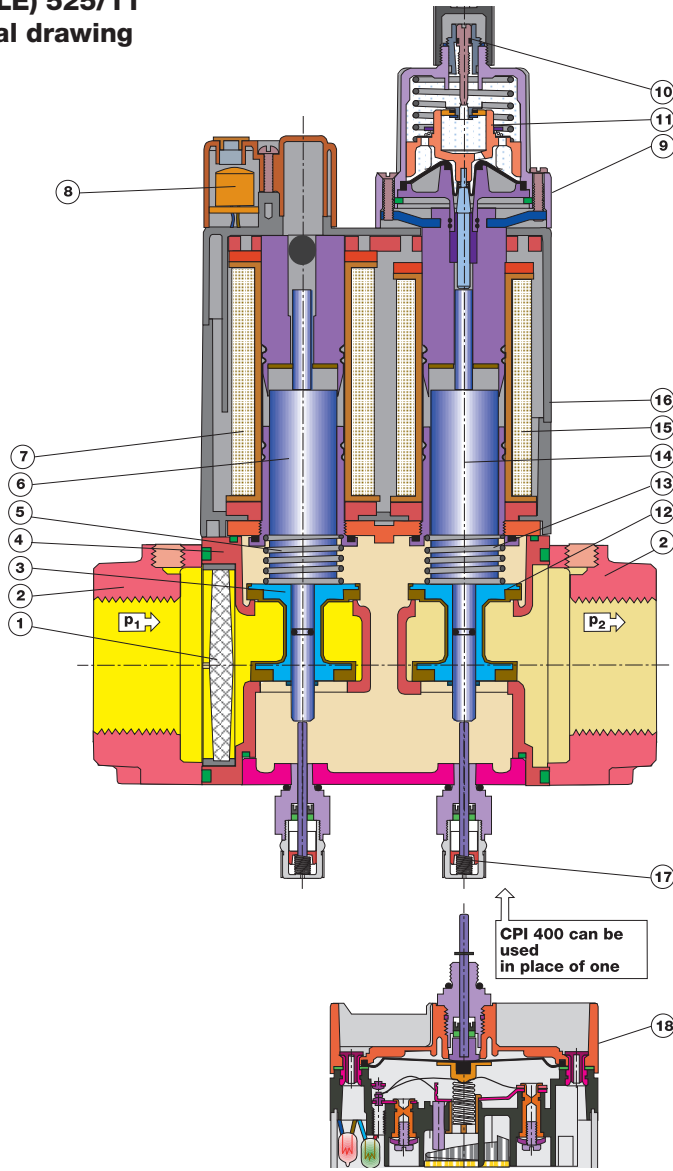

- 1 Strainer
- 2 Flange
- 3 Valve V1
- 4 Housing
- 5 Closing spring V1
- 6 Plunger V1
- 7 Solenoid V1
- 8 Electrical connection
- 9 Max flow adjustment
- 10 Initial lift adjustment (DMV-DLE)
- 11 Hydraulic brake (DMV-DLE)
- 12 Valve V2
- 13 Closing spring V2
- 14 Plunger V2
- 15 Solenoid V2
- 16 Solenoid housing
- 17 Visual indicator (VI)
- 18 CPI 400 interlock switch

## PRESSURE DROP FOR OTHER GASES

To determine the pressure drop when using a gas other than natural gas, use the flow formula below and f value located in the chart below to determine the “corrected” flow rate in CFH through the valve for the other gas used. For example, when using propane, divide the volume (CFH) of propane required for the application by the calculated value f (f = 0.66 for propane). Use this “corrected” flow rate and the flow curve on the next page to determine pressure drop for propane.

$$\dot{V}_{\text{gas used}} = \dot{V}_{\text{Natural Gas}} \times f$$

Use this formula to calculator the f factor for other gases not listed on the table.

$$f = \sqrt{\frac{\text{Spec. gravity of Natural Gas}}{\text{Spec. gravity of gas used}}}$$

Type of gas used	Density [kg/m <sup>3</sup> ]	sg	f
Natural gas	0.81	0.65	1.00
Butane	2.39	1.95	0.58
Propane	1.86	1.50	0.66
Air	1.24	1.00	0.80

**Dual Modular Safety  
Shutoff Valves  
DMV-D 525/11  
DMV-DLE 525/11**



**Flow curve**

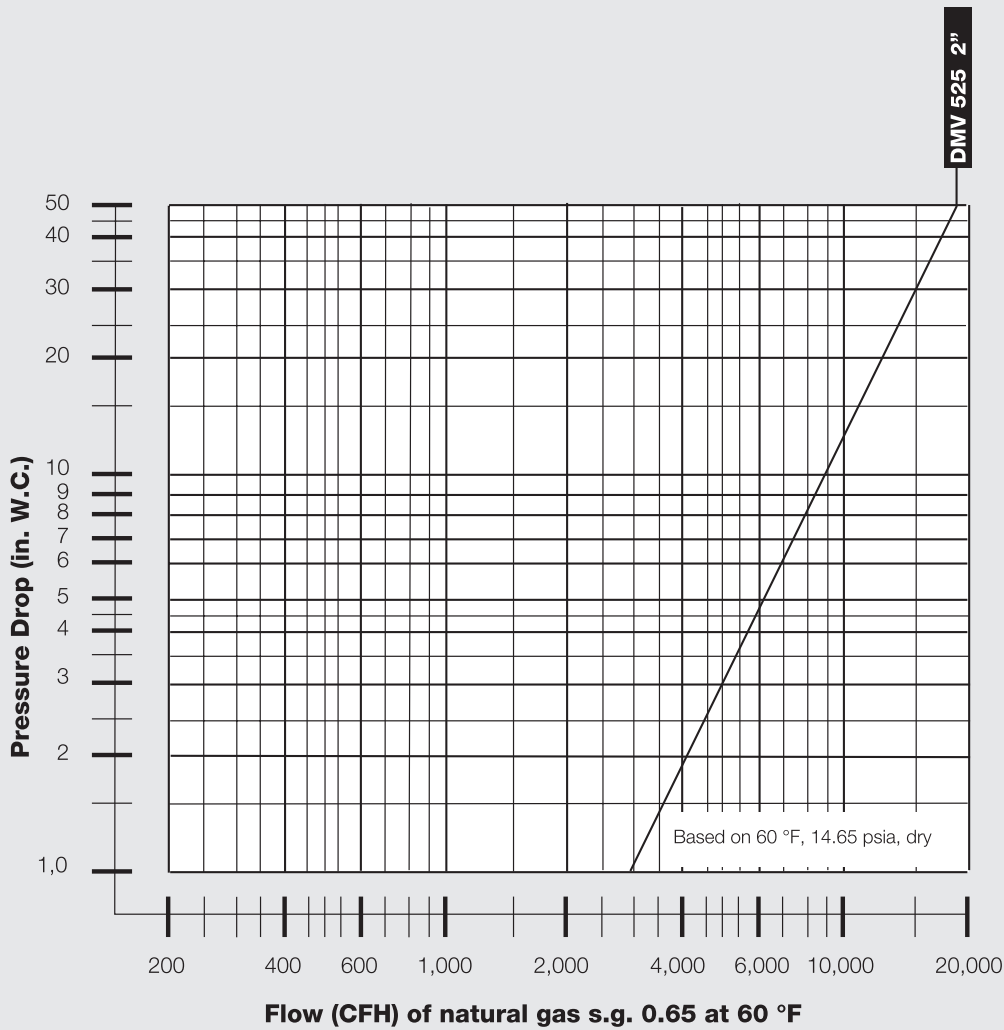

We reserve the right to make any changes in the interest of technical progress.

**Karl Dungs Inc.**  
524 Apollo Drive, Suite 10  
Lino Lakes, MN 55014, U.S.A.  
Phone 651 792-8912  
Fax 651 792-8919  
e-mail [info@karldungsusa.com](mailto:info@karldungsusa.com)  
Internet <http://www.dungs.com/usa/>

**Karl Dungs GmbH & Co. KG**  
P.O. Box 12 29  
D-73602 Schorndorf, Germany  
Phone +49 (0)7181-804-0  
Fax +49 (0)7181-804-166  
e-mail [info@dungs.com](mailto:info@dungs.com)  
Internet <http://www.dungs.com>