

CAUTION: Read carefully before operation.

OPERATION

The duplex strainer or filter design includes two basket chambers with a built in transfer valve to provide uninterrupted flow during basket change-overs on fluid handling systems. The normal flow of fluid is through the intake port, then through the upper port of the valve, the inside of the basket where particles are trapped, the bottom port of the valve, and finally through the discharge port of the unit. To direct the flow from one basket chamber to the other, swing the valve handle (Fig. 1) to either of its extreme positions. The chamber in use is shown by the indicator which is cast into the valve handle and partially covers the chamber in use. The opposite chamber can then be opened and the basket removed for cleaning. It is not necessary to drain the strainer chamber in order to remove the basket, although it can be helpful.

REMOVING THE BASKET

The basket can be easily removed from the chamber not in use by unscrewing the yoke handle, or on high pressure models, stud nuts, and removing the cover. Care should be taken not to damage the cover gasket. The basket can be easily lifted out of the chamber and cleaned. When replacing the cover of the basket chamber, be sure the cover seat is clean and the cover not cocked to one side. As the handle or cover stud nut is screwed down, tension is placed on the basket handle which holds the basket firmly in place while in use.

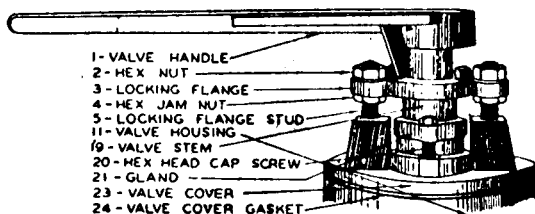

Fig. 1

PRESSURE EQUALIZATION

Kraissl duplex strainers have tapered valve plugs which are adjusted at the factory. In operation, one side of the valve is exposed to the fluid pressure and the other side may be exposed to atmospheric pressure. With the valve properly adjusted, there will be only slow pressure equalization. The pressure on the one

side will tend to press the tapered plug against the low pressure side. This contact, if the pressure is great enough, causes the valve to lock in position. To remedy this condition, we provide an equalization assembly, where required. Kraissl 5", 6" and 8" and all high pressure models are supplied with this assembly. It has been found that pressure equalization is required when used above the following pressures:

<u>SIZE</u>	<u>MODEL</u>	<u>PRESSURE</u>
3/4 -1 1/2 "	72-31 to 72-37	100 psig
2 to 3"	72-39 to 43	80 psig
4"	72-47	15 psig
5" & Over	72-49+	All pressures

The assembly consists of a needle valve, appropriate reducing bushings, a length of copper tubing and a tubing elbow which connect to the basket chambers on the clean fluid side as indicated in Fig. 2. When supplied, the needle valve is removed during shipment to avoid possible breakage in transit. Before operating, be sure to screw the needle valve in the open reducing bushing and fasten the free end of the copper tubing to the tubing connection of the valve. Use of pipe cement is recommended on the screwed joint to insure tightness.

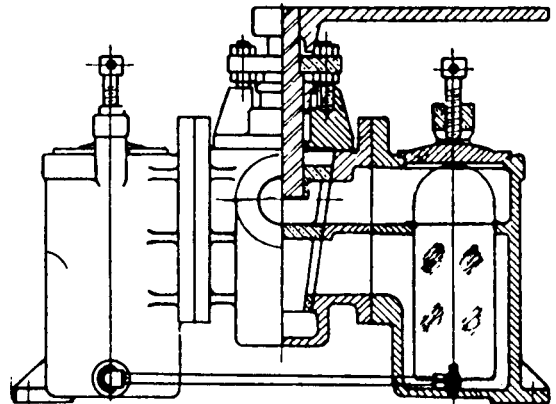

Fig. 2

THE KRAISSL COMPANY
INCORPORATED

HACKENSACK, NEW JERSEY



OPERATION & MAINTENANCE OF
KRAISSL MODEL 72 SERIES DUPLEX
STRAINERS & FILTERS

A1710B

CAUTION: Read carefully before operation.

When it is desired to shift operation of the strainer from one basket to the other, first open the needle valve in the equalization line so that the pressure in both chambers is about the same. Second, swing the valve, to the other chamber, using the handle provided. The handle should move easily when the pressure is equalized. Third, close the needle valve in the line, before opening the cover of the basket chamber. When a strainer or filter is used with hot liquid, a drain line or valve should be installed at the bottom of each side body to relieve pressure before opening the cover.

ADJUSTING THE VALVE PLUG

It is possible, even after pressure equalization described above, that under severe operating conditions, the valve plug assembly (Part 19) may become locked in position because of unequal expansion of adjacent parts. This can also occur if the strainer is accidentally hit or dropped on the valve stem. To free the valve plug, proceed as follows:

- A. Loosen hex nuts (Part 2) slightly and be sure the set screw in the handle (Part 1) hub is tight.
- B. Raise the tapered valve plug off the seat by external means.
- C. To readjust the valve, tighten the hex nuts (Part 2) evenly and a little at a time. While doing this, keep moving the valve plug assembly (Part 19) through its cycle of operation. When the action just begins to tighten, the valve is in proper adjustment. To determine if the valve is seeping too much liquid, remove the cover (Part 6) of the chamber not in use and note the rate of liquid level rising. If excessive, further tighten the valve plug assembly.
- D. To hold the assembly in position, turn the hex jam nuts (Part 4) up against the under side of the locking flange (Part 3) until tight. The unit is now ready for operation.

NOTE: DO NOT try to force the valve plug assembly through its cycle of operation. It should at all times, turn without the aid of any additional leverage other than the valve handle.

Each valve plug is individually mated with the valve seat to produce a close fit. Avoid putting pressure on the top of the valve plug

assembly as this could force the tapered plug too firmly on its seat and could result in damaging the seat faces.

OPTIONAL LIFTING JACK

For an alternative that raises and lowers the valve plug assembly before and after switching sides, see Bulletin B3522.

REPACKING THE STUFFING BOX

- A. Remove the valve handle (Part 1) and remove the Woodruff Key at hub (not shown).
- B. Remove the locking flange (Part 3) after first removing the hex nuts (Part 2).
- C. Remove the hex head cap screws (Part 20).
- D. Remove the gland (Part 21).
- E. The stuffing box may be repacked. Use a good grade of square valve stem packing.
- F. To replace component parts, reverse this procedure.

IDENTIFICATION OF PARTS PREFIX MODEL NUMBER OF UNIT BEFORE PART NUMBERS FOR COMPLETE IDENTIFICATION

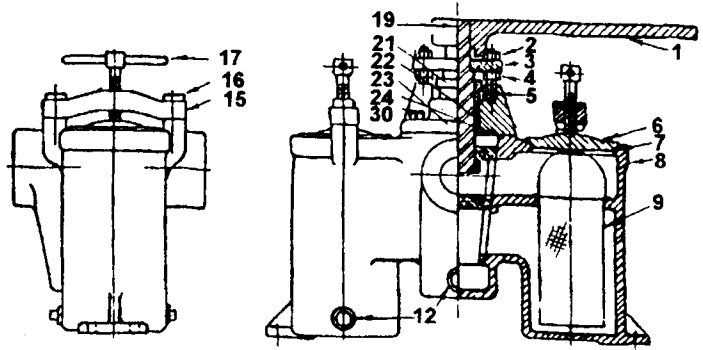

PART	NAME	PCS	PART	NAME	PCS
1	Valve Handle	1	16	Yoke Stud	4
2	Hex Nut	2	17	Yoke Handle	2
3	Locking Flange	1	19	Valve Plug Ass'y	1
4	Hex Jam Nut	2	20	Gland Cap Screw	2
5	Locking Flange Stud	2	21	Gland	1
6	Body Cover	2	22	Packing	1
7	BC Gasket	2	23	Valve Cover	1
8	Strainer Body	1	24	VC Gasket	1
9	Basket	2	28	Key	1
12	Drain Plug	5	29	Set Screw	1
15	Yoke	2	30	VC Cap Screw	4-8

Note: High pressure model 72H series duplex strainers have stud & nut body cover fastenings in lieu of yoke closure (Part#'s 15, 16 & 17).