

KRAISSL THREE PIECE DUPLEX STRAINERS & FILTERS MODEL 72AFS and 72AFHS SERIES CAST STEEL or STAINLESS STEEL

Pressure Range - 200 to 720 PSIG

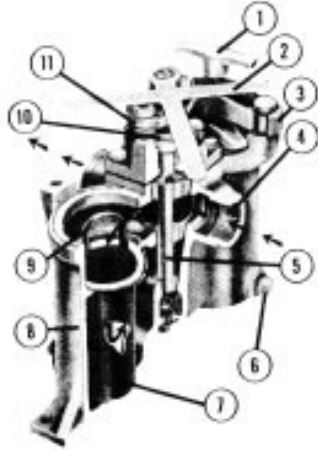

FEATURES

- 1 - Hand clamp requires no special tools.
- 2 - Valve handle shields side in use.
- 3 - Accessible swing yoke closure for easy basket cleaning.
- 4 - Continuous flow without interruption during changeover.
- 5 - Tapered valve plug for durability.
- 6 - Drain connections on each basket chamber.
- 7 - Interchangeable strainer, filter and double element baskets.
- 8 - Bodies individually pressure tested to U.L. specifications.
- 9 - Spring handle holds basket on seat.
- 10 - Independent gland for external stem packing access.
- 11 - Adjustable locking flange establishes valve clearance.
- 12 - Mounting feet provided.



A1879A (9704)



PURPOSE

Kraissl pipeline strainers and filters protect pumps, engines, nozzles, valves, heat exchangers and other expensive pipeline equipment from harmful flow contamination by catching dirt and debris.

APPLICATION

Kraissl duplex strainers and filters provide a simple, cost effective way to separate particle impurities from fluid systems. Duplex strainers are ideal for applications where continuous flow must be maintained with no flow interruption for basket cleaning.

Kraissl strainers are listed by Underwriters Laboratories, Inc. (U.L.) and are individually tested to U.L. quality control specifications. These cast pipeline strainers are manufactured according to international standard A.S.T.M. F1199 for use in industrial and marine applications.

DESIGN SPECIFICATIONS

Model 72AFS and 72AFHS series three piece duplex strainers are furnished in both standard or high pressure models with flanged port connections. The center valve section or side bodies can be separately removed and serviced independently. Threaded NPT, socket weld or butt weld end models are also available, described in other bulletins. Internal channels are 100% full-flow, having the same cross-sectional area as the equivalent pipe size. Standard pressure models are furnished with our quick-opening, hand-clamp closure for easy access. High pressure models have stud-and-nut / bolted body cover closures. Materials of construction include rugged cast carbon steel bodies, covers, and iron valve plugs, and brass, carbon steel, stainless steel or monel baskets. Special valve plugs can also be furnished in bronze, stainless steel or other materials. All stainless steel models are also available in cast 316 stainless steel, 304 stainless steel or other special stainless alloys.

These duplex strainers have a built-in, tapered plug valve that directs flow through either side without shutting off the flow. A valve handle guard shields the side in use. The standard valve handle swings over the inlet port. Special reverse valve handles that swing over the outlet port can also be furnished. Drain plugs are provided in each of the valve and basket chambers. An adjustable locking flange holds the valve plug on its seat. A separate external gland is provided to allow easy access to valve stem packing without complete disassembly, even while in service.

Strainer baskets are fabricated from perforated metal. The smallest common perforation size is 1/64 inch in brass and 1/32 inch in stainless steel. Filter baskets are manufactured by using fine mesh wire cloth over supporting perforated metal. Interchangeable strainer, filter and double element baskets provide a flexible range of operating choices. The basket is held on its seat by a spring basket handle. Normal flow is through the interior of the basket which then contains the collected debris when the basket is lifted out for cleaning. Reverse flow is also possible if desired. Magnet inserts are available to help eliminate fine metallic ferrous particles.

All high pressure ("H") models with stud and nut closure are supplied with balancing valve assemblies to equalize pressure and ease valve turning. These should be specified on standard pressure models when used above the following pressures: **3/4 inch through 1 1/2 inch inclusive - 100 psig; 2 inch through 3 inch - 80 psig; 4 inch through 8 inch -15 psig.**

An optional lifting jack can be provided to lift the valve plug off its seat for ease in valve turning in rough service on sizes 1 through 4 inch. A lifting jack is standard on 5, 6 and 8 inch sizes.

KRAISSL CAST STEEL * THREE PIECE DUPLEX STRAINERS

MODEL 72A(F)S SERIES - CLASS 150

HAND CLAMP (YOKE) CLOSURE

For Standard Pressure to 200 psig

MODEL 72A(F)HS SERIES - CLASS 300**

STUD AND NUT COVER CLOSURE

For High Pressure to 720 psig

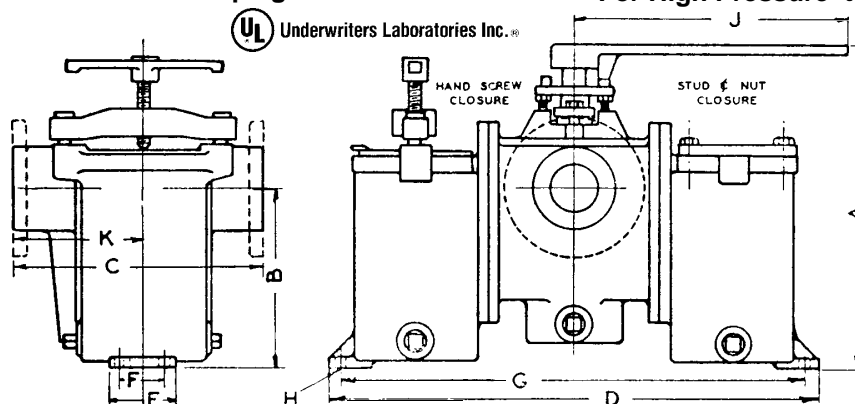

OUTLINE DIMENSIONS

MODEL NO	PIPE SIZE	APPROX NET WGT, LBS		A	B	C		D	E	F	G	H	J	K	
		CL 150	CL 300			CL 150	CL 300							CL 150	CL 300
72-31A(H)S	3/4"NPT	69	69	11 9/16	5 1/16	7 5/8	7 5/8	15 1/4	2 1/8	1 1/4	14 3/8	7/16	12 1/8	3 7/8	3 7/8
72-33A(H)S	1" NPT	69	69	11 9/16	5 1/16	7 5/8	7 5/8	15 1/4	2 1/8	1 1/4	14 3/8	7/16	12 1/8	3 7/8	3 7/8
72-35A(H)S	1/4"NP	78	78	12	5 1/2	7 5/8	7 5/8	16 7/8	2 3/8	1 1/2	16	7/16	12 1/8	3 7/8	3 7/8
72-37A(H)S	1/2"NP	87	87	13 1/2	7	7 5/8	7 5/8	16 7/8	2 3/8	1 1/2	16	7/16	12 1/8	3 7/8	3 7/8
72-33AF(H)S	1"	73	77	11 9/16	5 1/16	9 3/8	9 3/8	15 1/4	2 1/8	1 1/4	14 3/8	7/16	12 1/8	4 15/16	4 15/16
72-37AF(H)S	1 1/2"	93	100	13 1/2	7	9 3/8	9 3/8	16 7/8	2 3/8	1 1/2	16	7/16	12 1/8	4 15/16	4 15/16
72-39AF(H)S	2"	165	173	15	7 7/8	12	12	22 3/4	3	1 7/8	21 3/4	9/16	12 1/8	6 1/4	6 1/4
72-41AF(H)S	2 1/2"	209	218	16 7/8	9 3/4	12 5/8	12 5/8	25 5/8	3	1 7/8	24 9/16	9/16	12 1/8	6 1/2	6 1/2
72-43AF(H)S	3"	250	263	17 1/16	9 13/16	12 1/2	12 1/2	29 1/2	3 1/4	2	28 1/4	9/16	12 1/8	6 7/8	6 7/8
72-47AF(H)S	4"	325	339	20 3/4	13 1/2	15 5/8	15 5/8	31 1/2	3 1/4	2	30 3/8	9/16	12 1/8	9	9
72-49AF(H)S**	5"	670	-	23	13 1/2	18	18	42 9/16	2 3/4	4 1/2	41 9/16	9/16	14	10 1/8	10 1/8
72-51AF(H)S**	6"	790	-	26 1/4	16 1/4	21	21	44 9/16	2 3/4	4 1/2	43 9/16	9/16	14	12	12

Dimensions are in inches and subject to casting and production variations.

*ASTM A216 WCB - Cast Carbon Steel. Cast 304 SS - ASTMA351-CF8. Cast 316 SS - ASTM 351-CF8M.

**Special Model 72AFHS-150 series with Class 150 Flanges for 230 psig and Model 72AFHS-600 series for 1480 psig Max. W.P. also available. Please contact factory. A lifting jack is standard on 5" and 6" sizes. 5" and 6" sizes not listed by Underwriters' Laboratories, Inc.

DOUBLE ELEMENT BASKET DATA

The open area ratios of two perforated metal sizes are given below. Baskets are available in all standard perforations and meshes. Filter baskets are made of wire mesh cloth spotwelded over supporting cylinder of perforated metal.

DOUBLE ELEMENT BASKETS

These units can be supplied with our patented double-element baskets which are easily disassembled for cleaning and provide greater straining areas in the same housing.

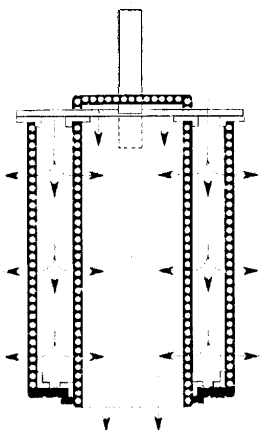

A1879A (9704)

CAT. NOS.	INCH PIPE SIZE	INTERNAL PIPE AREA SQ. IN.	BASKET DIMENSIONS		TOTAL SCREEN AREA SQ. IN.	APPROX. OPEN SCREEN AREA SQ. IN.		RATIO OF OPEN AREA TO PIPE AREA	
			O. D.	LENGTH		1/16" HOLE DIA.*	1/32" HOLE DIA.**	1/16" HOLE DIA.*	1/32" HOLE DIA.**
72-31AS	3/4	0.533	1 15/16	3 15/16	26.9	10.8	7.5	20.3:1	14.1:1
72-33A(F)(H)S	1	0.864	1 15/16	3 15/16	26.9	10.8	7.5	12.5:1	8.7:1
72-37A(F)(H)S	1 1/2	2.036	2 9/16	5	45.4	18.2	12.7	12.2:1	8.5:1
72-39A(F)(H)S	2	3.355	3 1/2	5 1/8	66.0	26.4	18.5	7.9:1	5.5:1
72-41A(F)(H)S	2 1/2	4.788	4 1/8	6 1/4	94.4	37.8	26.4	7.9:1	5.5:1
72-43AF(H)S	3	7.393	4 1/8	7	101	40.4	28.3	5.5:1	3.8:1
72-47AFHS	4	12.73	4 1/8	11	149	59.6	41.7	4.7:1	3.3:1
72-49AFHS	5	20.01	6 7/8	9 1/4	237	94.8	66.4	4.7:1	3.3:1
72-51AFHS	6	28.89	6 7/8	12	296	118	82.9	4.7:1	2.9:1

* Based on 40% open area.

**Based on 28% open area.

OTHER PRODUCTS

Our product lines of cast iron, bronze, aluminum, steel and stainless steel simplex and duplex strainers including NPT cast iron models are covered in separate bulletins. Units can also be furnished in other special metals and higher pressure / temperature ratings.



Represented By:
Power Equipment Company
2011 Williamsburg Road
Richmond, VA 23231
Ph. 804-236-3800
Fx. 804-236-3882
www.peconet.com