

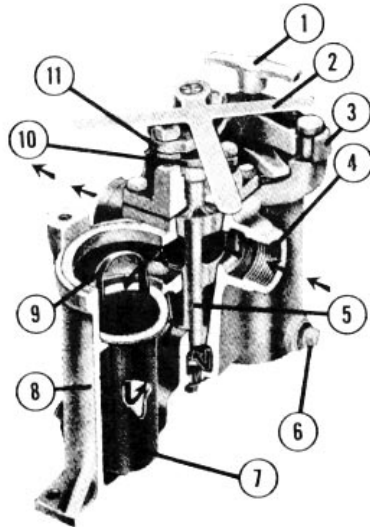

KRAISSL DUPLEX STRAINERS AND FILTERS

MODEL 72S and 72HS SERIES - CAST STEEL and STAINLESS STEEL

Pressure Range - 200 to 720 PSIG



FEATURES

- 1 - Hand clamp requires no special tools on low pressure models.
- 2 - Valve handle shields side in use.
- 3 - Accessible swing yoke closure for easy basket cleaning.
- 4 - Continuous flow without interruption during changeover.
- 5 - Tapered valve plug for durability.
- 6 - Drain connections on each basket chamber.
- 7 - Interchangeable strainer, filter and double element baskets.
- 8 - Bodies individually pressure tested to U.L. specifications.
- 9 - Spring handle holds basket on seat.
- 10 - Independent gland for external stem packing access.
- 11 - Adjustable locking flange establishes valve clearance.
- 12 - Mounting feet provided.

KRAISSL COMPANY, INC.

A2210A (9612)



PURPOSE

Kraissl pipeline strainers and filters protect pumps, nozzles, valves, heat exchangers and other expensive pipeline equipment from harmful contamination by catching dirt and debris.

APPLICATION

Kraissl duplex strainers and filters provide a simple, cost effective way to separate particle impurities from fluid systems. Duplex strainers are ideal for applications where continuous flow must be maintained, with no flow interruption for basket cleaning.

Kraissl strainers are listed by Underwriters Laboratories, Inc. (U.L.), and are individually tested to U. L. quality control specifications. These cast pipeline strainers are manufactured according to international standard A.S.T.M. F1199 for use in industrial and marine applications.

DESIGN SPECIFICATIONS

Model 72 and 72H series duplex strainers are furnished in both standard or high pressure models with NPT, socket weld or butt weld port connections. Flanged models are also available, described in other bulletins. Internal channels are 100% full-flow, having the same cross-sectional area as the equivalent pipe size. Standard pressure models are furnished with our quick-opening, hand-clamp closure for easy access. High pressure models are furnished with stud-and-nut body cover closure. Refer to our drawings A2334A and A2345 for sizes, ratings and dimensions.

Materials of construction include rugged cast steel or stainless steel bodies and covers; cast iron or bronze valve plugs, and brass, carbon steel, stainless steel or monel baskets. Special valve plugs can also be furnished in stainless steel or other materials.

These duplex strainers have a built-in, tapered plug valve that directs flow through either side without shutting off the flow. A valve handle guard shields the side in use. The standard valve handle swings over the inlet port. Special reverse valve handles that swing over the outlet port can also be furnished. Drain plugs are provided in each of the valve and basket chambers. An adjustable locking flange holds the valve plug on its seat. A separate, external gland is provided to allow easy access to valve stem packing without complete disassembly, even while in service.

Strainer baskets are fabricated from perforated metal. The smallest common perforation size is 1/64 inch in brass and 1/32 inch in stainless steel. Filter baskets are manufactured by using fine mesh wire cloth over supporting perforated metal. Interchangeable strainer, filter and double element baskets provide a flexible range of operating choices. The basket is held on its seat by a spring basket handle. Normal flow is through the interior of the basket which then contains the collected debris when the basket is lifted out for cleaning. Reverse flow is also possible if desired. Magnet inserts are available to help eliminate fine metallic ferrous particles.

All high pressure models with stud-and-nut closure are supplied with balancing valve assemblies to equalize pressure and ease valve turning. These should be specified on standard pressure models when used above the following pressures: 3/4" through 1-1/2" inclusive, 100psig; 2" & 2-1/2", 80 psig.

An optional lifting jack can be provided to lift the valve plug off its seat for ease in valve turning in rough service.

KRAISSL CAST STEEL * DUPLEX STRAINERS THREADED (NPT) PORTS

MODEL 72S(S) SERIES HAND CLAMP (YOKE) CLOSURE For Standard Pressure to 200 psig

MOD. NO.	PIPE SIZE NPT	APPROX. NET WGT. LBS.	A	B	C	D	E	F	G	H	J	K
72-31DS	3/4"	33	10 1/8	5 7/16	5 1/4	10 3/4	2 1/4	1 1/2	10 1/8	7/16	8 1/8	2 3/4
72-33DS	1"	33	10 1/8	5 7/16	5 1/4	10 3/4	2 1/4	1 1/2	10 1/8	7/16	8 1/8	2 3/4
72-31S	3/4"	42	12 1/4	6 1/8	6 3/4	14 1/2	2 3/4	1 3/4	13 1/2	7/16	12 1/8	3 5/8
72-33S	1"	42	12 1/4	6 1/8	6 3/4	14 1/2	2 3/4	1 3/4	13 1/2	7/16	12 1/8	3 5/8
72-35S	1 1/4"	56	13 1/4	8 1/8	7 5/8	14 1/8	2 1/4	1 3/4	13 1/4	7/16	12 1/8	4
72-37S	1 1/2"	56	13 1/4	8 1/8	7 5/8	14 1/8	2 1/4	1 3/4	13 1/4	7/16	12 1/8	4
72-39S	2"	115	14 3/4	7 7/8	10 5/8	20 1/2	3	1 7/8	19 1/2	9/16	12 1/8	5 9/16
72-41S	2 1/2"	115	14 3/4	7 7/8	10 5/8	20 1/2	3	1 7/8	19 1/2	9/16	12 1/8	5 9/16

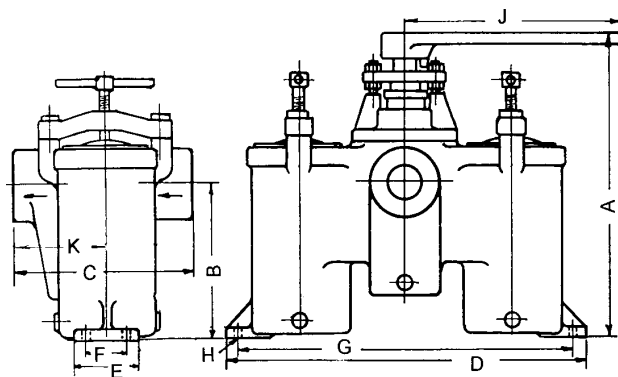

MODEL 72HS(S) SERIES STUD AND NUT COVER CLOSURE For High Pressure to 720 psig

MOD. NO.	PIPE SIZE NPT	APPROX. NET WGT. LBS.	A	B	C	D	E	F	G	H	J	K
72-31HS	3/4"	42	12 1/4	6 1/8	6 3/4	14 1/2	2 3/4	1 3/4	13 1/2	7/16	12 1/8	3 5/8
72-33HS	1"	42	12 1/4	6 1/8	6 3/4	14 1/2	2 3/4	1 3/4	13 1/2	7/16	12 1/8	3 5/8
72-35HS	1 1/4"	56	13 1/4	8 1/8	7 5/8	14 1/8	2 1/4	1 3/4	13 1/16	7/16	12 1/8	4
72-37HS	1 1/2"	56	13 1/4	8 1/8	7 5/8	14 1/8	2 1/4	1 3/4	13 1/16	7/16	12 1/8	4
72-39HS	2"	115	14 3/4	7 7/8	10 5/8	20 1/2	3	1 7/8	19 1/2	9/16	12 1/8	5 9/16
72-41HS	2 1/2"	115	14 3/4	7 7/8	10 5/8	20 1/2	3	1 7/8	19 1/2	9/16	12 1/8	5 9/16

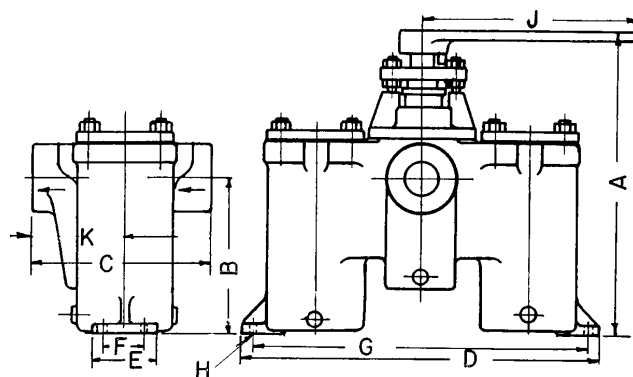

*ASTM A216 WCB.

Dimensions are in inches and subject to casting and production variations.

DOUBLE ELEMENT BASKETS

These units can be supplied with our patented double-element baskets which are easily disassembled for cleaning and provide greater straining areas in the same housing. Double-Element Baskets are listed by Underwriters Laboratories, Inc. for a variety of sizes.

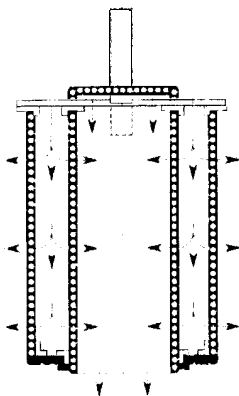

A2210A (9612)

SINGLE ELEMENT BASKET DATA

Use Double Element Baskets for greater straining area.

MOD. NOS.	INCH PIPE SIZE	INTERNAL PIPE AREA SQ. IN.	BASKET DIMENSIONS		TOTAL SCREEN AREA SQ. IN.	APPROX. OPEN SCREEN AREA SQ. IN.		RATIO OF OPEN AREA TO PIPE AREA	
			O. D.	LENGTH		1/16" HOLE DIA.*	1/32" HOLE DIA.**	1/16" HOLE DIA.*	1/32" HOLE DIA.**
72-31DS	3/4	0.533	1 15/16	3 15/16	26.9	10.8	7.5	20.3:1	14.1:1
72-33DS	1	0.864	1 15/16	3 15/16	26.9	10.8	7.5	12.5:1	8.7:1
72-31(H)S	3/4	0.533	1 15/16	3 15/16	26.9	10.8	7.5	20.3:1	14.1:1
72-33(H)S	1	0.864	1 15/16	3 15/16	26.9	10.8	7.5	12.5:1	8.7:1
72-35(H)S	1 1/4	1.495	1 15/16	6 3/8	41.8	16.7	11.7	11.2:1	7.8:1
72-37(H)S	1 1/2	2.036	1 15/16	6 3/8	41.8	16.7	11.7	8.2:1	5.7:1
72-39(H)S	2	3.355	3 1/2	5 1/8	66.0	26.4	18.5	7.9:1	5.5:1
72-41(H)S	2 1/2	4.788	3 1/2	5 1/8	66.0	26.4	18.5	5.5:1	3.9:1

* Based on 40% open area.

**Based on 28% open area.

OTHER PRODUCTS

Our product lines of bronze, steel and stainless steel simplex and duplex strainers including flanged, NPT and weld-end models are covered in separate bulletins. Units can also be furnished in other special metals and higher pressure / temperature ratings.



Represented By:
Power Equipment Company
2011 Williamsburg Road
Richmond, VA 23231
Ph. 804-236-3800
Fx. 804-236-3882
www.peconet.com