

SPARK AND SENSE ASSEMBLY

FOR USE ON BURNER APPLICATIONS WHERE ONLY ONE COMMON ROD IS AVAILABLE FOR BOTH ELECTRIC SPARK IGNITION AND SENSING PRESENCE OF THE FLAME.

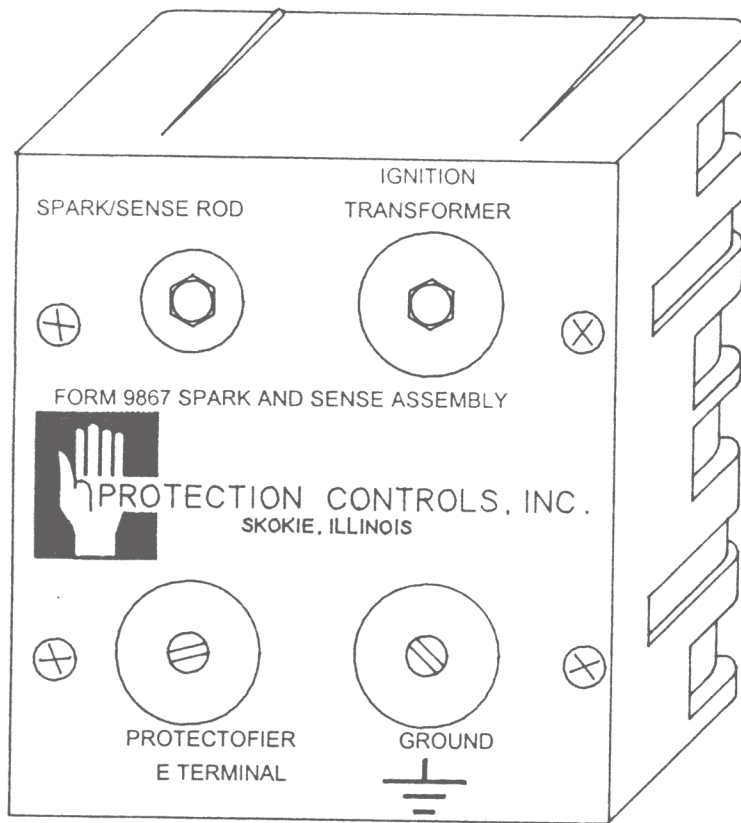

NOTES:

1. MULTI-BURNER APPLICATION REQUIRE ONE FORM 9867 SPARK AND SENSE ASSEMBLY AND ONE IGNITION TRANSFORMER FOR EACH BURNER POSITION.
2. THIS UNIT IS COMPATIBLE FOR USE WITH PROTECTOFIER FLAME SAFEGUARDS ONLY.
3. DIMENSIONS 4"H X 3 5/8"W X 4 1/4"D.
4. SPARK AND SENSE RODS' LENGTH, SPACING TO GROUND, AND POSITION MAY HAVE TO BE ALTERED FOR PROPER OPERATION.



PROTECTION CONTROLS, INC.

Power Equipment Company
Manufacturers Representative
 2011 Williamsburg Rd. Richmond, VA 23231
 (804) 236-3800 Fax (804) 236-3882

TYPICAL CIRCUIT FOR SINGLE BURNER (SHOWN WITH 120V. CONTROL CIRCUIT)

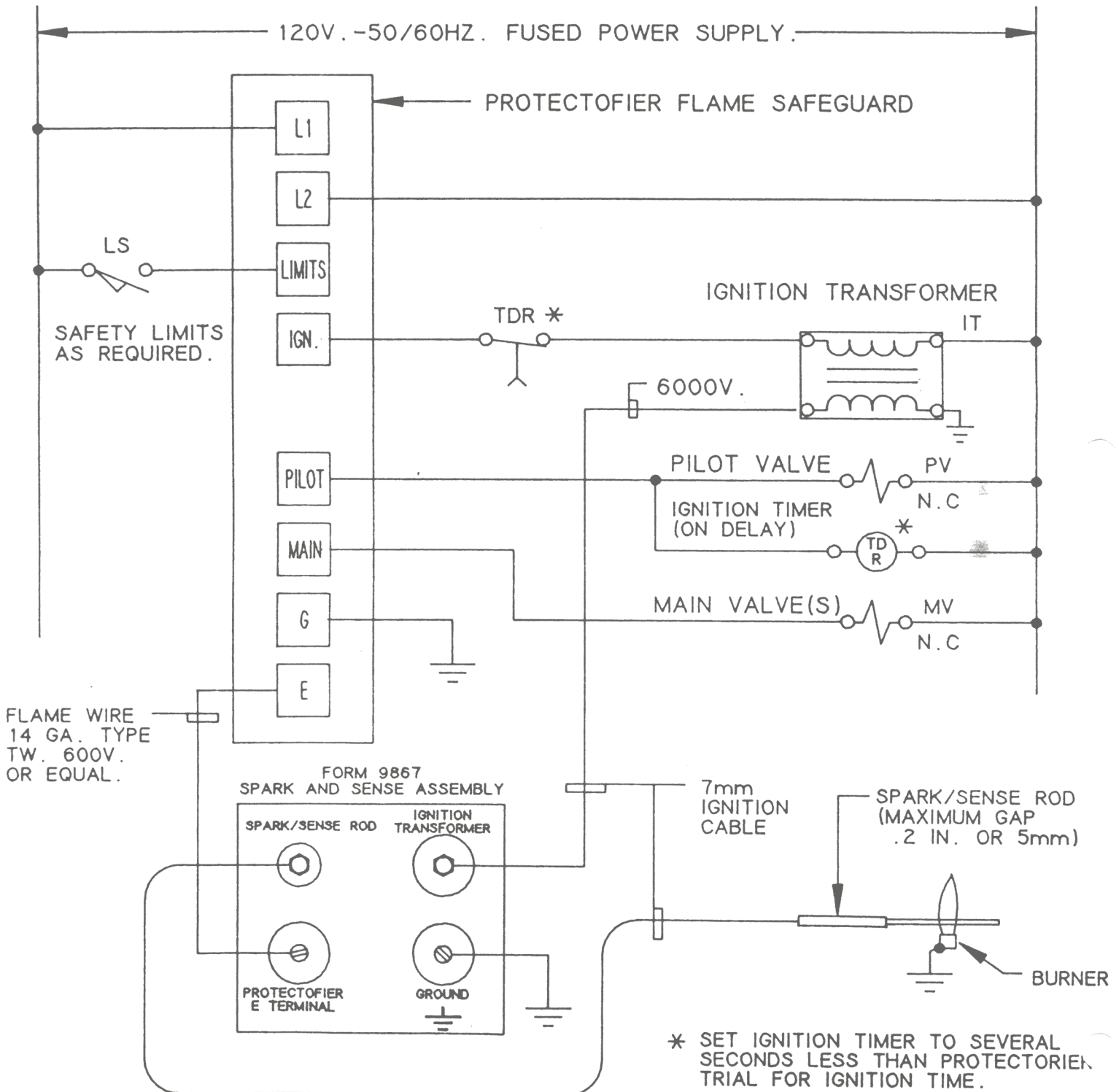

INSTALLATION, OPERATION AND MAINTENANCE SHALL COMFORM WITH NATIONAL FIRE PROTECTION ASSOCIATION STANDARDS, NATIONAL AND LOCAL CODES AND AUTHORITIES HAVING JURISDICTION.