

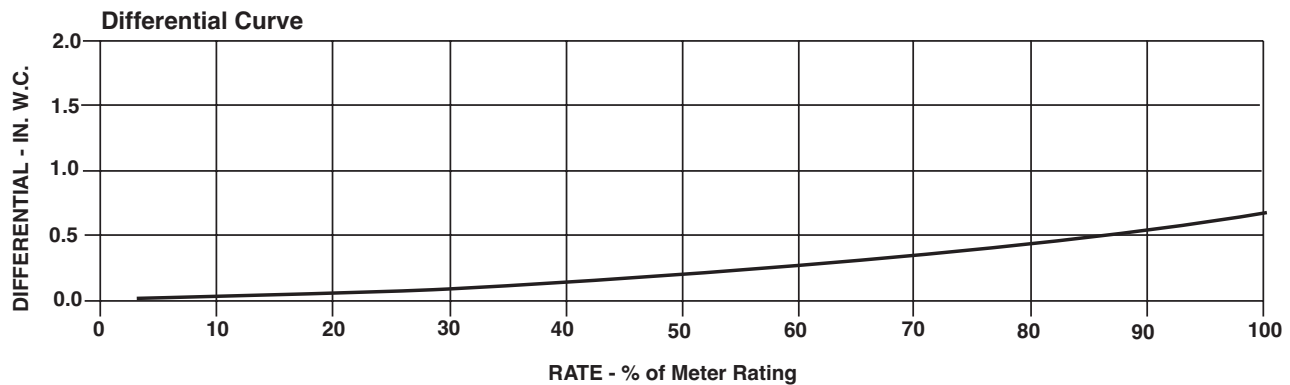

SERIES B3: 15C175 ROOTS® Meter

	UNITS	Imperial	UNITS	Metric
Temperature Range	deg. F	-40 to +140	deg. C	-40 to +60
Base Rating (Q Max.)	acfh	1500	m ³ /h	42,5
Max. Operating Pressure (MAOP) ¹	psig	175	kPa	1200
Leak Test (125% MAOP)	psig	219	kPa	1510
Static Test (2 x MAOP)	psig	350	kPa	2400
Rangeability +/- 1%	ratio	40:1	ratio	40:1
Rangeability +/- 2%	ratio	78:1	ratio	78:1
Start Rate	cfh	1.94	m ³ /h	0,0549
Stop Rate	cfh	1.57	m ³ /h	0,0445
Flow Rate @ 0.5" w.c., Gas	cfh	1500	m ³ /h	42,5
Avg. Differential, 100% Flow	in. w.c.	0.75	mbar	1,9
Max. Pressurization Rate	psig/sec	5	kPa/sec	35
Max. Operating Speed	rpm	2500	rpm	2500
Gear Ratio	ratio	1000:1	ratio	352,9411:1
Displaced Volume/Revolution	cf	0.01	m ³	0,000283
Drive Rate, CD	cf/rev	10	m ³ /rev	0,1
Drive Rate, TD	cf/rev	100	m ³ /rev	1
Temp. Compensating Range (TC, TD)	deg. F	-20 to +120	deg. C	-20 to +50
Min. Odometer Reading	cf	0.2	m ³	0,002
Odometer Turnover	yrs.	7.61	yrs.	2,69
Nominal Pipe Size	in.	2	mm	50,8
Flange-to-Flange	in.	6-3/4	mm	172
Flange Connection	ANSI	150#FF	ANSI	150#FF
Bolts per Flange	qty.	4	qty.	4
Bolt Size ²	in.	5/8 - 11	in.	5/8 - 11
Flange Bolt Hole Depth	in.	15/16	mm	23,8
Bolt Torque: Lubricated/Non-Lub.	ft.-lb.	55/60	N-m	74/81
Restricting Orifice (120%)	in.	3/8	mm	9,5
Oil Capacity – Side Inlet	oz.	0.8	ml	24
Oil Capacity – Top Inlet	oz.	3	ml	89
Counter Version (CTR) ³				
Net Weight	lbs.	24	kg	10,9
Shipping Weight	lbs.	27	kg	12,2
Carton Size	in.	22 x 10-1/8 x 7-3/4	cm	55 x 26 x 19
Counter with Instrument Drive (CD) ³				
Net Weight	lbs.	27	kg	12,2
Shipping Weight	lbs.	30	kg	13,6
Carton Size	in.	22 x 10-1/8 x 7-3/4	cm	55 x 26 x 19

NOTES:¹ Available with 200 PSIG rating.² Bolt Length varies by application.³ Weights and dimensions available for CPS, TC, TD, TPS upon request.

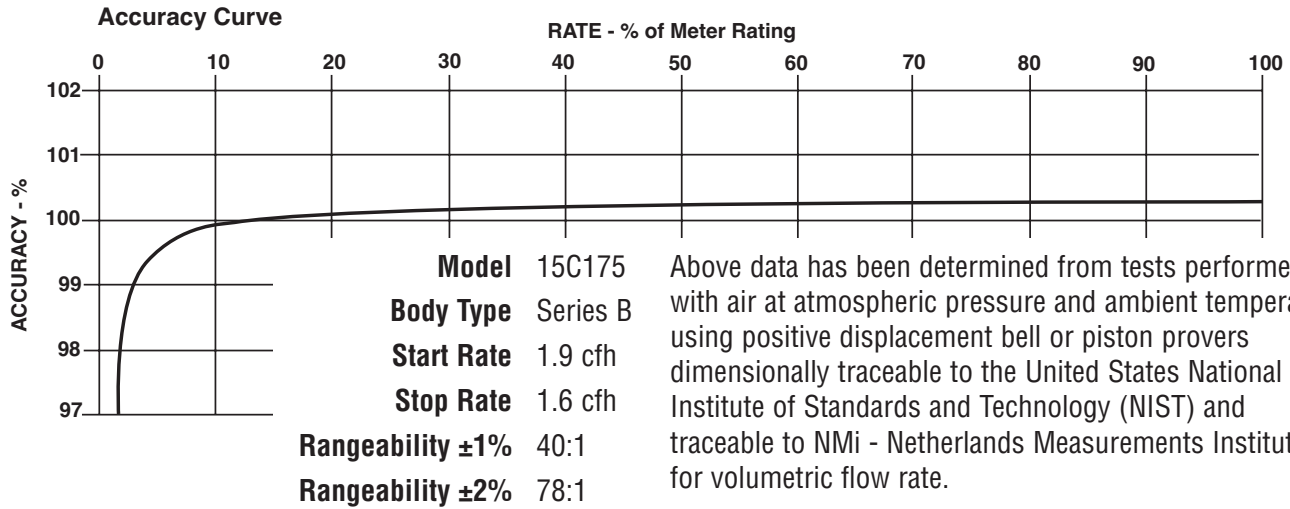

15C175 Series B3	Overall Length		Overall Height		Width (Flange/Flange)		Centerline to Accessory End (CL-AU)		Request Detailed Drawing Number
	inches	mm	inches	mm	inches	mm	inches	mm	
CTR /TC	15-7/16	392	6	153	6-3/4	172	9-1/4	255	D054516-000
CD/TD	19-1/16	485	6-9/32	160	6-3/4	172	13-7/8	353	D054430-000
ICPS/ ITPW/ICEX	16-13/16	427	6	153	6-3/4	172	11-5/8	295	D057415-000
IMC/W2	20-11/16	525	6	153	6-3/4	172	15-9/32	388	D056701-000

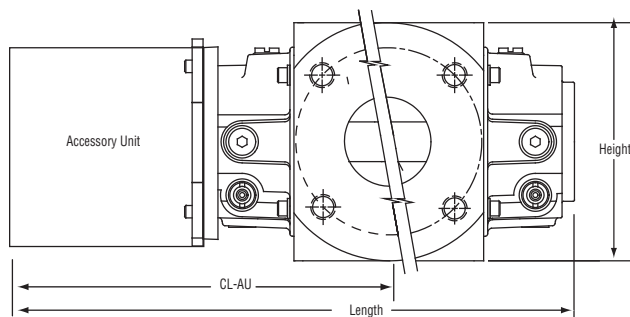

To order

Specify: Meter Series, Size and Type (i.e., ROOTS Meter Series B3 15C175 CD).
 For CD or TD, specify Inlet (Top or Side) and ID Rotation (CW-B or CCW-A).
 For Pulsar, specify Single or Dual Connectors and Connector Type (MS Circular, Conduit or Cable Gland).
 For more specific ordering information on the electronic products, request: TS:SSP or TS:IMC/W2.
 Contact the factory for other available information, options, or special requests.

POWER EQUIPMENT COMPANY
 2011 WILLIAMSBURG ROAD
 RICHMOND, VIRGINIA 23231
 (804) 236-3800 (FAX) (804) 236-3882
www.peconet.com

