

SERIES B3: 2M175 ROOTS® Meter

	UNITS	Imperial	UNITS	Metric
Temperature Range	deg. F	-40 to +140	deg. C	-40 to +60
Base Rating (Q Max.)	acfh	2000	m ³ /h	56,6
Max. Operating Pressure (MAOP)	psig	175	kPa	1200
Leak Test (125% MAOP)	psig	219	kPa	1510
Static Test (2 x MAOP)	psig	350	kPa	2400
Rangeability +/- 1%	ratio	68:1	ratio	68:1
Rangeability +/- 2%	ratio	126:1	ratio	126:1
Start Rate	cfh	1.9	m ³ /h	0,0538
Stop Rate	cfh	1.1	m ³ /h	0,0311
Flow Rate @ 0.5" w.c., Gas	cfh	2000	m ³ /h	56,6
Avg. Differential, 100% Flow	in. w.c.	0.65	mbar	1,6
Max. Pressurization Rate	psig/sec	5	kPa/sec	35
Max. Operating Speed	rpm	1667	rpm	1667
Gear Ratio	ratio	500:1	ratio	176,4705:1
Displaced Volume/Revolution	cf	0.02	m ³	0,000566
Drive Rate, CD	cf/rev	10	m ³ /rev	0,1
Drive Rate, TD	cf/rev	100	m ³ /rev	1
Temp. Compensating Range (TC, TD)	deg. F	-20 to +120	deg. C	-20 to +50
Min. Odometer Reading	cf	0.2	m ³	0,002
Odometer Turnover	yrs.	5.7	yrs.	2,02
Nominal Pipe Size	in.	2	mm	50,8
Flange-to-Flange	in.	6-3/4	mm	172
Flange Connection	ANSI	150#FF	ANSI	150#FF
Bolts per Flange	qty.	4	qty.	4
Bolt Size ¹	in.	5/8 - 11	in.	5/8 - 11
Flange Bolt Hole Depth	in.	15/16	mm	23,8
Bolt Torque: Lubricated/Non-Lub.	ft.-lb.	55/60	N-m	74/81
Restricting Orifice (120%)	in.	7/16	mm	11,113
Oil Capacity – Side Inlet	oz.	1.25	ml	37
Oil Capacity – Top Inlet	oz.	7.65	ml	226
Counter Version (CTR) ²				
Net Weight	lbs.	26	kg	11,8
Shipping Weight	lbs.	28	kg	12,7
Carton Size	in.	26 x 10-5/16 x 7-3/4	cm	66 x 25 x 19
Counter with Instrument Drive (CD) ²				
Net Weight	lbs.	30	kg	13,6
Shipping Weight	lbs.	32	kg	14,5
Carton Size	in.	26 x 10-5/16 x 7-3/4	cm	66 x 25 x 19

NOTES:
¹ Bolt Length varies by application.

² Weights and dimensions available for GPS, TC, TD, TPS upon request.

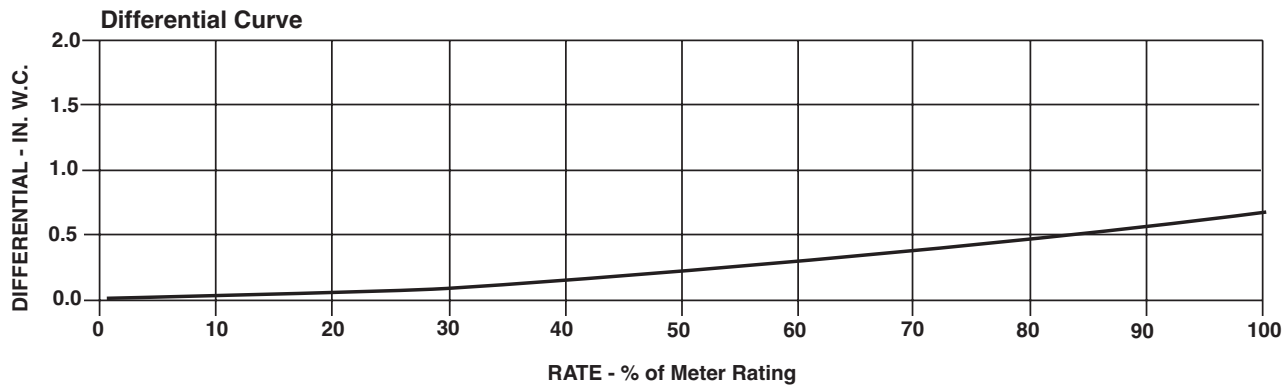
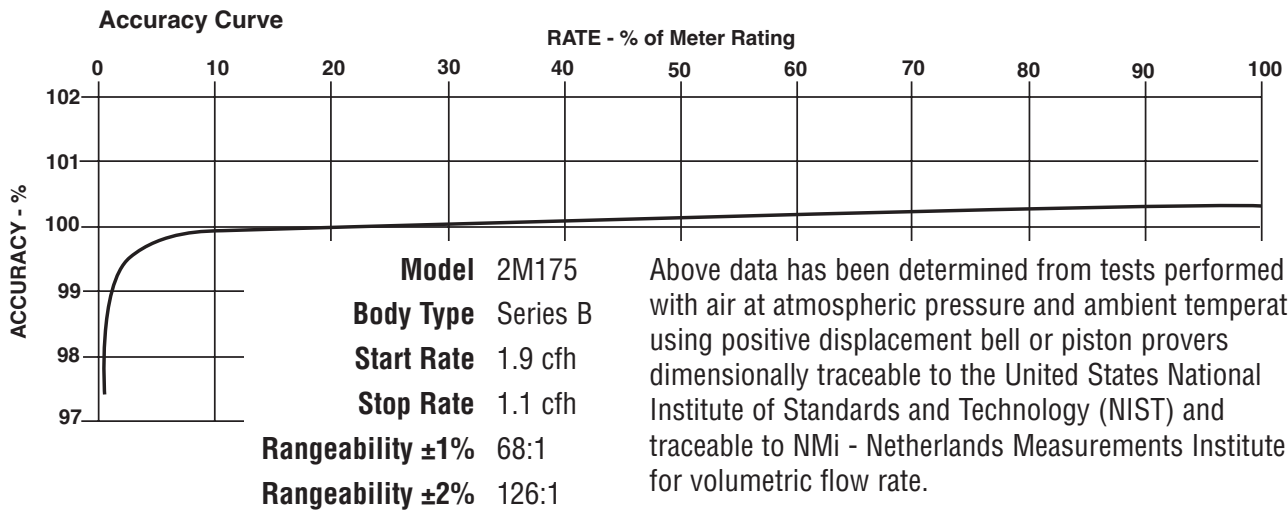

2M175 Series B3	Overall Length		Overall Height		Width (Flange/Flange)		Centerline to Accessory End (CL-AU)		Request Detailed Drawing Number
	inches	mm	inches	mm	inches	mm	inches	mm	
CTR/TC	15-7/8	403	6-31/32	177	6-3/4	172	10-3/16	259	D054517-000
CD/TD	19-25/32	503	6-31/32	177	6-3/4	172	14-1/8	359	D054431-000
ICPW/ITPW/ICEX	17-3/8	441	6-31/32	177	6-3/4	172	11-3/4	298	D056900-000
IMC/W2	20-13/32	518	6-31/32	177	6-3/4	172	14-3/4	375	D056702-000

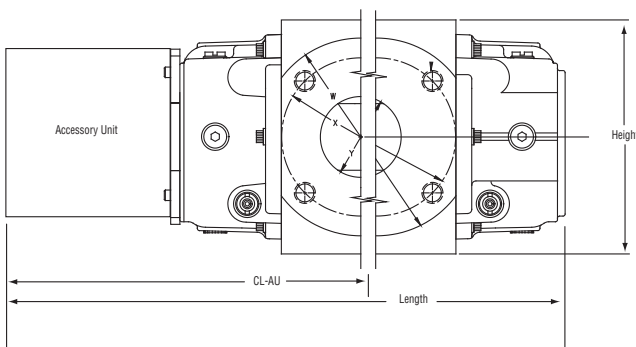

To order

Specify: Meter Series, Size and Type (i.e., ROOTS Meter Series B3 2M175 CD).
 For CD or TD, specify Inlet (Top or Side) and ID Rotation (CW-B or CCW-A).
 For Pulsar, specify Single or Dual Connectors and Connector Type (MS Circular, Conduit or Cable Gland).
 For more specific ordering information on the electronic products, request: TS:SSP or TS:IMC/W2.
 Contact the factory for other available information, options, or special requests.

POWER EQUIPMENT COMPANY
 2011 WILLIAMSBURG ROAD
 RICHMOND, VIRGINIA 23231
 (804) 236-3800 FAX (804) 236-3882
www.peconet.com

