



SERIES B3: 3M175 ROOTS® Meter

	UNITS	Imperial	UNITS	Metric
Temperature Range	deg. F	-40 to +140	deg. C	-40 to +60
Base Rating (Q Max.)	acfh	3000	m ³ /h	85
Max. Operating Pressure (MAOP)	psig	175	kPa	1200
Leak Test (125% MAOP)	psig	219	kPa	1510
Static Test (2 x MAOP)	psig	350	kPa	2400
Rangeability +/- 1%	ratio	76:1	ratio	76:1
Rangeability +/- 2%	ratio	139:1	ratio	139:1
Start Rate	cfh	2.1	m ³ /h	0,0595
Stop Rate	cfh	1.8	m ³ /h	0,0510
Flow Rate @ 0.5" w.c., Gas	cfh	2580	m ³ /h	73,1
Avg. Differential, 100% Flow	in. w.c.	1.05	mbar	2,6
Max. Pressurization Rate	psig/sec	5	kPa/sec	35
Max. Operating Speed	rpm	2000	rpm	2000
Gear Ratio	ratio	400:1	ratio	141,1764:1
Displaced Volume/Revolution	cf	0.025	m ³	0,000708
Drive Rate, CD	cf/rev	10	m ³ /rev	0,1
Drive Rate, TD	cf/rev	100	m ³ /rev	1
Temp. Compensating Range (TC, TD)	deg. F	-20 to +120	deg. C	-20 to +50
Min. Odometer Reading	cf	0.2	m ³	0,002
Odometer Turnover	yrs.	3.8	yrs.	1,34
Nominal Pipe Size	in.	2	mm	50,8
Flange-to-Flange	in.	6-3/4	mm	172
Flange Connection	ANSI	150#FF	ANSI	150#FF
Bolts per Flange	qty.	4	qty.	4
Bolt Size ¹	in.	5/8 - 11	in.	5/8 - 11
Flange Bolt Hole Depth	in.	15/16	mm	23,8
Bolt Torque: Lubricated/Non-Lub.	ft.-lb.	55/60	N-m	74/81
Restricting Orifice (120%)	in.	17/32	mm	9,525
Oil Capacity – Side Inlet	oz.	1.25	ml	37
Oil Capacity – Top Inlet	oz.	7.65	ml	226
Counter Version (CTR) ²				
Net Weight	lbs.	29	kg	13,2
Shipping Weight	lbs.	31	kg	14,1
Carton Size	in.	26 x 10-15/16 x 7-3/4	cm	66 x 25 x 19
Counter with Instrument Drive (CD) ²				
Net Weight	lbs.	33	kg	15,0
Shipping Weight	lbs.	38	kg	17,2
Carton Size	in.	26 x 10-15/16 x 7-3/4	cm	66 x 25 x 19

NOTES:

¹ Bolt Length varies by application.

² Weights and dimensions available for CPS, TC, TD, TPS upon request.

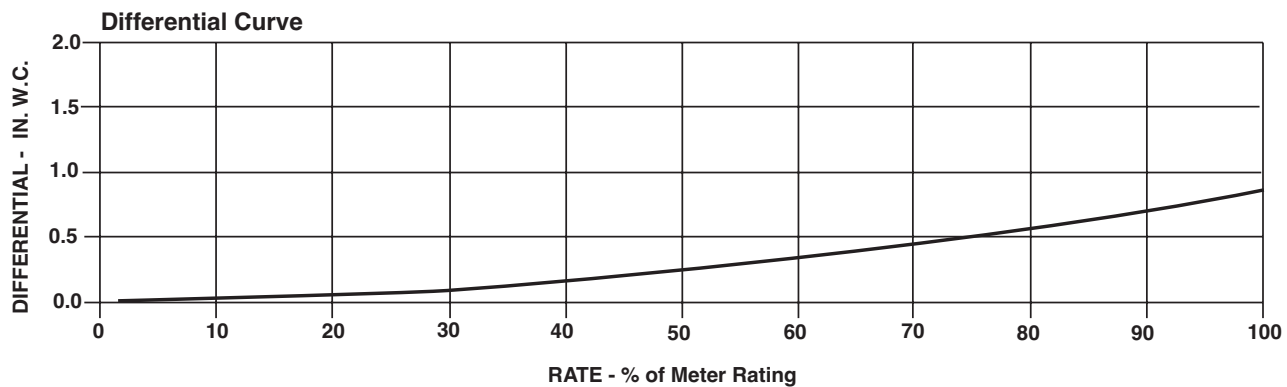
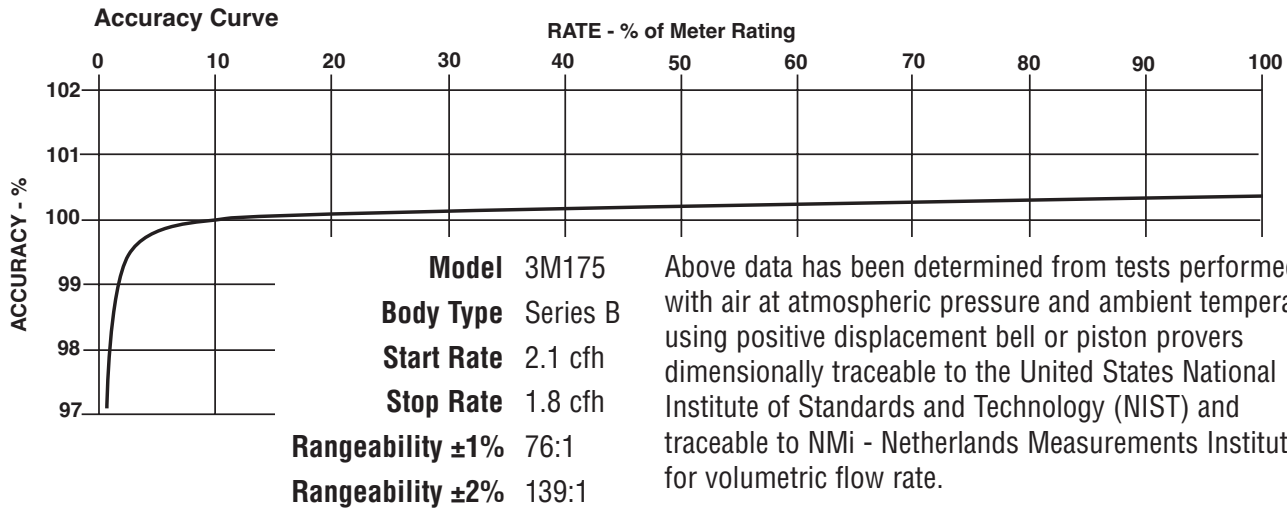

3M175 Series B3	Overall Length		Overall Height		Width (Flange/Flange)		Centerline to Accessory End (CL-AU)		Request Detailed Drawing Number
	inches	mm	inches	mm	inches	mm	inches	mm	
CTR/TC	17-1/16	433	6-31/32	177	6-3/4	172	10-13/16	274	D054517-000
CD/TD	20-31/32	533	6-31/32	177	6-3/4	172	14-23/32	374	D054431-000
ICPW/ITPW/ICEX	18-5/8	473	6-31/32	177	6-3/4	172	12-3/8	314	D056900-000
IMC/W2	21-5/8	549	6-31/32	177	6-3/4	172	15-3/8	391	D056702-000

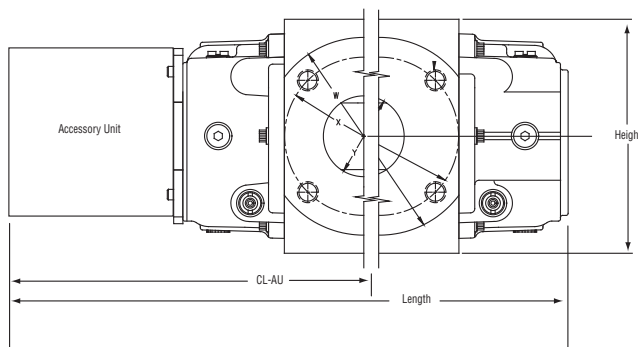

To order

Specify: Meter Series, Size and Type (i.e., ROOTS Meter Series B3 3M175 CD).
 For CD or TD, specify Inlet (Top or Side) and ID Rotation (CW-B or CCW-A).
 For Pulsar, specify Single or Dual Connectors and Connector Type (MS Circular, Conduit or Cable Gland).
 For more specific ordering information on the electronic products, request: TS:SSP or TS:IMC/W2.
 Contact the factory for other available information, options, or special requests.

POWER EQUIPMENT COMPANY
 2011 WILLIAMSBURG ROAD
 RICHMOND, VIRGINIA 23231
 (804) 236-3800 (FAX) (804) 236-3882
www.peconet.com

