



SERIES B3-HPC: 11M1480 ROOTS® Meter

	UNITS	Imperial	UNITS	Metric
Temperature Range	deg. F	-40 to +140	deg. C	-40 to +60
Base Rating (Q Max.)	acfh	11,000	m ³ /h	312
Max. Operating Pressure (MAOP)	psig	1480	kPa	10204
Leak Test (125% MAOP)	psig	1850	kPa	12755
Static Test (200% MAOP)	psig	2960	kPa	20408
Rangeability +/- 1%	ratio	55:1	ratio	55:1
Rangeability +/- 2%	ratio	110:1	ratio	110:1
Start Rate	acfh	12.83	m ³ /h	0,363
Stop Rate	acfh	4.65	m ³ /h	0,132
Flow Rate @ 0.5" w.c., Gas	acfh	3.77	m ³ /h	0,107
Avg. Differential, 100% Flow	in. w.c.	1.04	mbar	0,029
Max. Pressurization Rate	psig/sec	5	kPa/sec	34
Max. Operating Speed	rpm	1467	rpm	1467
Gear Ratio	ratio	80:1	ratio	80:1
Displaced Volume/Revolution	acf/rev	0.125	m ³ /rev	0,0035
Drive Rate, CD	acf/rev	10	m ³ /rev	N/A
Min. Odometer Reading	acf	0.2	m ³	0,002
Odometer Turnover ¹	yrs.	1.04	yrs.	1.04
Nominal Pipe Size	in.	4	mm	101,6
Flange-to-Flange	in.	14-3/4	mm	374,65
Flange Connection	ANSI	600#RF	ANSI	600#RF
Bolts per Flange	qty.	8	qty.	8
Bolt Size ²	in.	7/8 - 9	in.	7/8 - 9
Flange Bolt Hole Depth	in.	1.875	mm	47.625
Bolt Torque: Lubricated/Non-Lub.	ft.-lb.	100/125	N-m	135/169
Restricting Orifice (100% @ MFR)	in.	0.891	mm	22,6
Oil Capacity - Side Inlet	oz.	14	ml	414
Oil Capacity - Top Inlet	oz.	34	ml	1006
Counter Version				
Net Weight	lbs.	277	kg	125,6451
Shipping Weight	lbs.	347	kg	157,3965
Carton Size	in.	26 x 16 x 19	cm	66 x 41 x 49
Counter with Instrument Drive				
Net Weight	lbs.	280	kg	127,00584
Shipping Weight	lbs.	350	kg	158,7573
Carton Size	in.	33 x 16 x 19	cm	84 x 41 x 49

NOTES:

Weights for ICEx/ICPWS/ICPWD/IMC/W2 available upon request.

1 Based on a yearly average of 100% MFR (odometer maximum reading of 100,000,000-cf)

2 Bolt Length varies by application.

Accuracy Curve

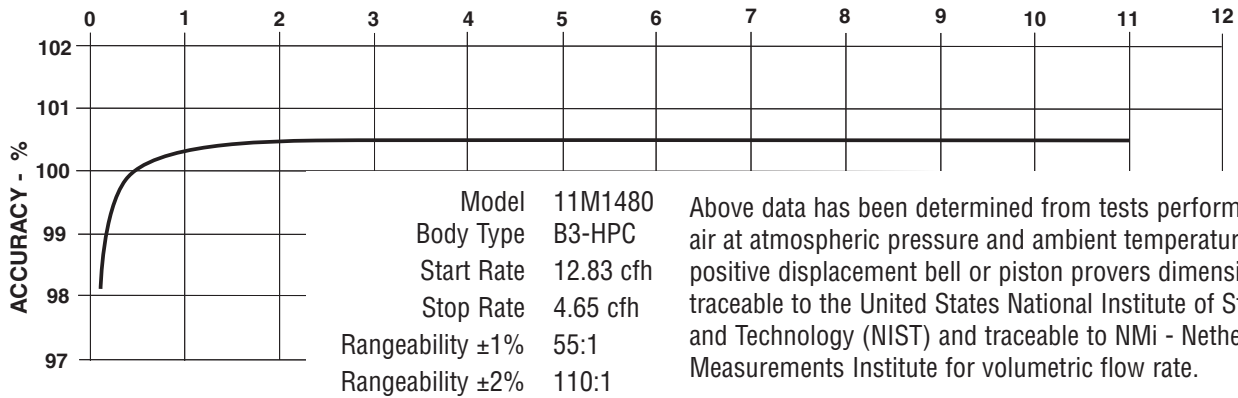

Differential Curve

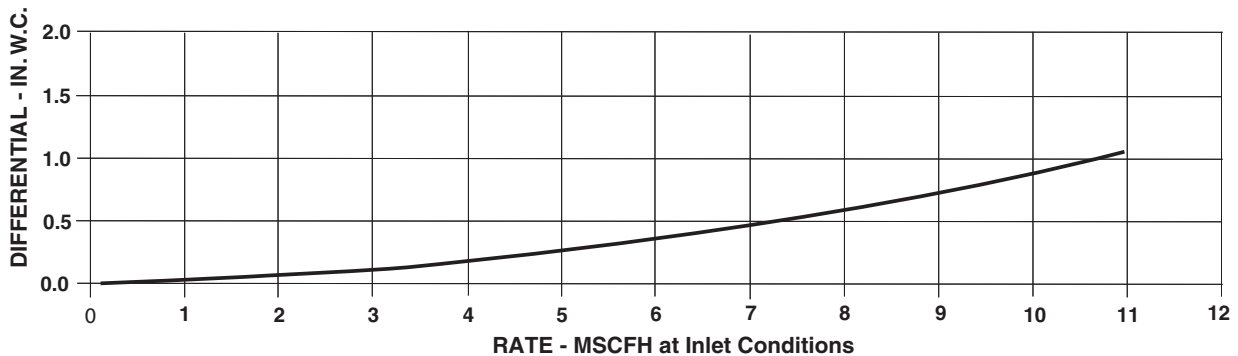

11M1480 Series B3-HPC	Overall Length		Overall Height		Width (Flange/Flange)		Centerline to Accessory End (CL-AU)		Request Detailed Drawing Number
	inches	mm	inches	mm	inches	mm	inches	mm	
CTR	22 5/32	563	14 9/32	363	14 3/4	375	12 31/32	329	059633-000
CD	25 31/32	660	14 9/32	363	14 3/4	375	16 25/32	426	059329-000
ICEX/ICPW/S-D	23 15/16	608	14 9/32	363	14 3/4	375	14 3/4	374	059535-000
IMC/W2	14.281	608	14 3/4	363	14 3/4	375	14 3/4	374	059374-000

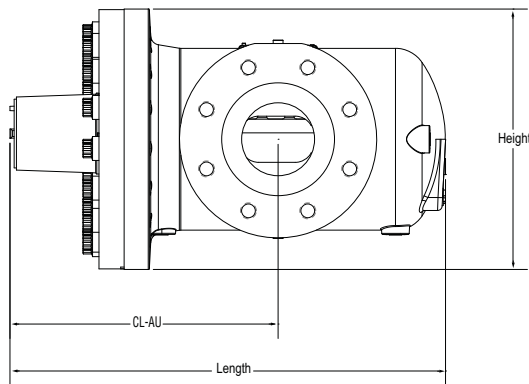

To order

Specify: Meter Series, Size and Type (i.e., ROOTS Meter Series B3-HPC 11M1480 CTR).
 For CD, specify Inlet (Top or Side) and ID Rotation (CW-B or CCW-A).
 For Pulser, specify Single or Dual Connectors and Connector Type (MS Circular, Conduit, or Cable Gland).
 For more specific ordering information on the electronic products, request: TS:SSP, TS:ICEX, or TS:IMC/W2.
 Contact the factory for other available information, options, or special requests.

POWER EQUIPMENT COMPANY
 2011 WILLIAMSBURG ROAD
 RICHMOND, VIRGINIA 23231
 (804) 236-3800 (FAX) (804) 236-3882
www.peconet.com

