



Burner controls

LMG...

Burner controls for the supervision of 1- or 2-stage gas or forced draft gas / oil burners of small to medium capacity (typically up to 350 kW) in intermittent operation.

The LMG... and this Data Sheet are intended for OEMs which integrate the burner controls in their products.

Use

LMG... are designed for the startup and supervision of 1- or 2-stage gas or forced draft gas / oil burners in intermittent operation. The flame is supervised with an ionization probe or a UV flame detector QRA... (with ancillary unit AGQ2 ...A27). LMG21... / LMG22... in the same housing replace burner controls LGB21... / LGB22... (refer to «Type summary») and – with the help of the relevant adapters – burner controls LFI7... and LFM1... (refer to «Ordering»).

Application-specific features

- Detection of undervoltages
- Air pressure supervision with functional check of the air pressure switch during startup and operation (only LMG2...)
- Electrical remote reset
- Display of error code and flame signal by signal lamps in the lockout reset button
- Accurate control sequence thanks to digital signal processing

Warning notes



To avoid injury to persons, damage to property or the environment, the following warning notes should be observed!

Do not open, interfere with or modify the unit!

- All activities (mounting, installation and service work, etc.) must be carried out by qualified staff
- Before performing any wiring changes in the connection area of the LMG..., completely isolate the burner control from the mains supply (all-polar disconnection)
- Ensure protection against electric shock hazard by providing adequate protection for the burner control's connection terminals
- Check to ensure that wiring is in an orderly state
- Check the connecting lines of the air pressure switch for short-circuits (connection terminals 3, 6 and 11)
- Press the lockout reset button / operation button only manually (applying a force of no more than 10 N), without using any tools or pointed objects
- Fall or shock can adversely affect the safety functions. Such units must not be put into operation, even if they do not exhibit any damage

Engineering notes

- On applications with actuators, the actuator does not deliver a position feedback signal to the burner control
- The actuator's running times must be matched to the burner control's program. An additional safety check of the burner together with the actuator must be made

Mounting notes

- Ensure that the relevant national safety regulations are complied with

Installation notes

- Always run the high-voltage ignition cables separate from the unit and other cables while observing the greatest possible distance
- Do not mix up live and neutral conductors
- Install switches, fuses, earthing, etc., in compliance with local regulations
- The connection diagrams shown apply to burner controls with an earthed neutral conductor. In the case of ionization current supervision in networks with non-earthed neutral conductor, terminal 2 must be connected to the earth conductor via an RC unit (part no. ARC 4 668 90660). It must be made certain that local regulations are complied with (e.g. protection against electric shock hazard) since AC 230 V / 50 Hz mains voltage produces peak leakage currents of 2.7 mA
- Make certain that the maximum permissible current rating of the connection terminals will not be exceeded
- Do not feed external mains voltage to the control outputs of the burner control. When testing the devices controlled by the LMG... (fuel valves, etc.), the burner control must never be plugged in
- In the case of burners with no fan motor, an AGK25 must be connected to terminal 3 of the unit, or else the burner cannot reliably be started up
- For safety reasons, feed the neutral conductor to terminal 2. As shown below, the burner components (fan, ignition transformer and gas valves) must be connected to the neutral distributor. The connection between neutral distributor and terminal 2 is prewired in the base of the unit

Example

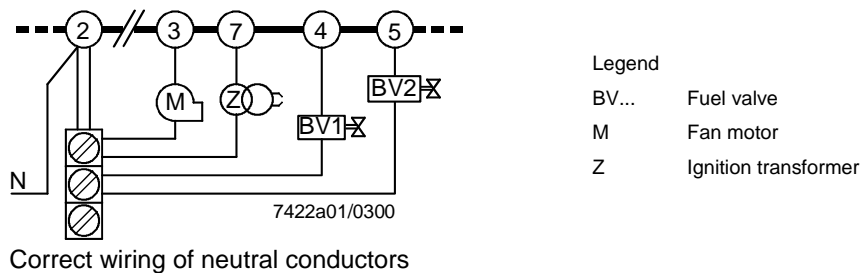

Electrical connection of flame detector

It is important to achieve practically disturbance- and loss-free signal transmission:

- Never run the detector cable together with other cables
 - Line capacitance reduces the magnitude of the flame signal
 - Use a separate cable
- Observe the permissible length of the detector cables (refer to «Technical data»)
- The ionization probe is not protected against electric shock hazard
- Locate the ignition electrode and ionization probe such that the ignition spark cannot arc over to the ionization probe (risk of electrical overloads) and that it cannot adversely affect the supervision of ionization
- Insulation resistance
 - Must be a minimum of 50 M Ω between ionization probe and ground
 - Soiled detector holders reduce the insulation resistance, thus supporting creepage currents
- Earth the burner in compliance with the relevant regulations; earthing the boiler alone does not suffice

Commissioning notes

- Prior to commissioning, check to ensure that wiring is in an orderly state
- When commissioning the plant or when doing maintenance work, make the following safety checks:

	Safety check	Anticipated response
a)	Burner startup with open-circuit to the ionization probe	Lockout at the end of «TSA»
b)	Burner operation with simulated loss of flame; for that purpose, cut off the gas supply	Immediate lockout Only with LMG25.../LMG49.031...: Restart followed by lockout at the end of «TSA»
c)	Burner operation with simulated air pressure failure (not with atmospheric burners)	Immediate lockout

Standards and certificates



Conformity to EEC directives

- Electromagnetic compatibility EMC (immunity) 89 / 336 EEC
- Directive for gas-fired appliances 90 / 396 EEC
- Low-voltage directive 73 / 23 EEC



ISO 9001: 2000
Cert. 00739



ISO 14001: 1996
Cert. 38233

Type reference				
LMG21.130B27	x	x	x	x
LMG21.230B27	x	x	x	x
LMG21.330B27	x	x	x	x
LMG21.350B27	x	x	x	x
LMG21.530B27	x	x	x	---
LMG21.550B27	x	x	x	x
LMG22.130B27	x	x	x	x
LMG22.230B27	x	x	x	x
LMG22.233B27	x	x	x	x
LMG22.330B27	x	x	x	x
LMG25.230B27	x	x	x	x
LMG25.330B27	x	x	x	x
LMG25.350B27	x	x	x	x
LMG49.030B27	---	---	x	---
LMG49.031B27	---	---	x	---

- Identification code to EN 298
 - LMG21... / LMG22... FTLLXN
 - LMG25... FTCLXN
 - LMG49... ATLLXN

Service notes

- Every time a unit has been replaced, check to ensure that wiring is in an orderly state and make the safety checks as specified in «Commissioning notes»
- Use service adapter KF8872 for short periods of time only

Disposal notes



The unit contains electrical and electronic components and may not be disposed of together with domestic waste.
Local and currently valid legislation must be observed.

Mechanical design

- LMG...
- Units of plug-in design like their predecessor types LGB2... (refer to «Dimensions»)
 - Housing made of impact-proof and heat-resistant plastic
 - The housing accommodates:
 - The microcontroller with the PCB relay for load control
 - The electronic flame signal amplifier (ionization)
 - The lockout reset button with the integrated red signal lamp and the green flame signal lamp
- Versions
- LMG21... / LMG22... Burner capacity unlimited (thermal output on startup ≤ 120 kW)
Lockout in the event of loss of flame during operation
 - LMG25... Burner capacity ≤ 120 kW
3 repetitions in the event of loss of flame during operation
-
- LMG49.030B27 Lockout in the event of loss of flame during operation
 - LMG49.031B27 1 repetition in the event of loss of flame during operation

Type summary

The type references given below refer to the LMG... with no plug-in base and with no flame detector.
For ordering information on the plug-in bases and other accessories, refer to «Ordering».

Type of flame detector	Type reference of burner control	tw min. 1)	t1 min.	TSA max.	t3n ap-prox.	t3 ap-prox.	t4 ap-prox.	t10 min. 1)	t11 max. 2)	t12 max. 2)	Behavior in the event of loss of flame during operation
Burner controls for prepurging with low-fire air volume, without actuator control											
Ionization probe (ION) or UV flame detector QRA.... (with ancillary unit AGQ2 ...A27)	LMG21.130B27 ³⁾	2.5 s	7 s	3 s	2 s	2 s	8 s	5 s	---	---	Lockout
	LMG21.230B27 ⁴⁾	2.5 s	20 s	3 s	2 s	2 s	8 s	5 s	---	---	Lockout
	LMG21.330B27 ⁴⁾	2.5 s	30 s	3 s	2 s	2 s	8 s	5 s	---	---	Lockout
	LMG21.350B27 ⁴⁾	2.5 s	30 s	5 s	4 s	2 s	10 s	5 s	---	---	Lockout
	LMG21.530B27	2.5 s	50 s	3 s	2 s	2 s	8 s	5 s	---	---	Lockout
LMG21.550B27 ⁴⁾	2.5 s	50 s	5 s	4 s	2 s	10 s	5 s	---	---	Lockout	
Burner controls for prepurging with nominal air volume, with actuator control											
Ionization probe (ION) or UV flame detector QRA.... (with ancillary unit AGQ2 ...A27)	LMG22.130B27 ³⁾	2.5 s	7 s	3 s	2 s	3 s	8 s	3 s	12 s	12 s	Lockout
	LMG22.230B27 ⁴⁾	2.5 s	20 s	3 s	2 s	3 s	8 s	3 s	16.5 s	16.5 s	Lockout
	LMG22.233B27	2.5 s	20 s	3 s	2 s	3 s	8 s	3 s	30 s	30 s	Lockout
	LMG22.330B27 ⁴⁾	2.5 s	30 s	3 s	2 s	3 s	8 s	3 s	12 s	11 s	Lockout
Burner controls for prepurging with low-fire air volume, without actuator											
Ionization probe (ION) or UV flame detector QRA.... (with ancillary unit AGQ2 ...A27)	LMG25.230B27	2.5 s	20 s	3 s	2 s	2 s	8 s	5 s	---	---	Max. 3 repetitions
	LMG25.330B27	2.5 s	30 s	3 s	2 s	2 s	8 s	5 s	---	---	Max. 3 repetitions
	LMG25.350B27	2.5 s	30 s	5 s	4 s	2 s	10 s	5 s	---	---	Max. 3 repetitions
Burner controls for atmospheric burners											
Ionization probe (ION) or UV flame detector QRA.... (with ancillary unit AGQ2 ...A27)	LMG49.030B27 ⁵⁾	3.5 s	---	3 s	2 s	0.5 s	0.5 s	---	---	---	Lockout
	LMG49.031B27	3.5 s	---	3 s	2 s	0.5 s	1 s	---	---	---	Max. 1 repetition

Legend

TSA Ignition safety time
tw Waiting time
t1 Prepurge time
t3 Preignition time
t3n Postignition time
t4 Interval between release of «BV1» and release of «BV2»

1) Max. 65 s
2) Max. running time available for actuators «SA»; the actuator's running time must be shorter

t10 Specified time for air pressure signal
t11 Programmed opening time for actuator «SA»
t12 Programmed closing time for actuator «SA»

3) Also suited for use with flash-steam generators
4) Also suited for use with direct fired air heaters
5) Unit without «LP» supervision, for burners without fan up to 120 kW

Burner control (without plug-in base) refer to «Type summary»

Connection accessories for small burner controls refer to Data Sheet N7201

- Plug-in base AGK11...
- Cable holders AGK65..., AGK66, and AGK67...
- Cable strain relief elements for AGK67...

Connection accessories for small burner controls refer to Data Sheet N7203

- Plug-in base AGK13...
- Plug-in housing AGK56...
- Cover AGK68...

Flame detectors

- Ionization probe supplied by thirds
- UV detectors QRA... refer to Data Sheet N7712

Actuators SQN3... refer to Data Sheet N7808

Actuators SQN7... refer to Data Sheet N7804

Actuators SQN9... refer to Data Sheet N7806



Pedestal (empty housing) **AGK21**
For increasing the height to that of the LFM... or LFI7... (refer to «Dimensions»)



RC unit **ARC 4 668 9066 0**
For supervising the ionization current in networks with non-earthed neutral conductor



PTC resistor (AC 230 V) **AGK25**
For producing a burden on terminal 3 (on burners with no fan motor, e.g. atmospheric gas burners)



Ancillary unit for UV supervision

- Cable length 500 mm **AGQ2.1A27**
- Cable length 300 mm **AGQ2.2A27**

Can be fitted under the plug-in base (for size, refer to «Dimensions»)



Test adapter **KF8872**

- For checking the functioning of the burner on the plant
- Functional check with the signal lamps

Note: With no load on the output terminals, the respective signal lamp may light up

- Detector current measurement with jacks of 4 mm diameter



Adapters / replacement types

No rewiring required

New type of burner control	Type of adapter	Type of predecessor unit
LMG21... with adapter	KF8853-K	LF17...
	KF8880 ¹⁾	LFM1... / LFM1...-F
LMG2... with adapter	KF8853-K	LF17...
	KF8880 ¹⁾	LFM1...

¹⁾ Not for use with atmospheric burners!

For UV supervision, AGQ2... with additional external wiring is also required.

Technical data

General unit data	Mains voltage	AC 230 V +10/-15 %
	Mains frequency	50...60 Hz ±6 %
	Power consumption	12 VA
	Primary fuse	max. 10 A (slow)
	Built-in fuse	T6.3H250V to DIN 60 127
	Perm. mounting position	optional
	Input current at terminal 12	max. 5 A
	Weight	approx. 160 g
	Degree of protection	IP 40, to be ensured through mounting
	Perm. cable length terminal 1	max. 1 m at 100 pF / m (max. 3 m at 15 pF / m)
	Perm. cable length terminals 8 and 10	max. 20 m at 100 pF / m
	Perm. cable length other terminals	max. 3 m at 100 pF / m

Environmental conditions

Storage	DIN EN 60721-3-1
Climatic conditions	class 1K3
Mechanical conditions	class 1M2
Temperature range	-20...+60 °C
Humidity	< 95 % r.h.
Transport	DIN EN 60 721-3-2
Climatic conditions	class 2K3
Mechanical conditions	class 2M2
Temperature range	-20...+60 °C
Humidity	< 95 % r.h.
Operation	DIN EN 60 721-3-3
Climatic conditions	class 3K3
Mechanical conditions	class 3M2
Temperature range	-20...+60 °C
Humidity	< 95 % r.h.



Condensation, formation of ice and ingress of water are not permitted!

Perm. amperage	At $\cos\varphi \geq 0.6$	At $\cos\varphi = 1$
- Terminal 3	Max. 2.7 A (15 A during max. 0.5 s)	Max. 3 A
- Terminals 4, 5 and 7	Max. 1.7 A	Max. 2 A
- Terminal 10	Max. 1 A	Max. 1 A

Flame supervision with ionization probe

	At mains voltage $U_N = AC 230 V$
Detector voltage across terminals 1 and 2 or ground (AC voltmeter, $R_i \geq 10 M\Omega$)	$\leq U_N$
Switching thresholds (limit values)	
Switching on (flame on) (DC ammeter, $R_i \leq 5 k\Omega$)	$\geq 2 \mu A$
Switching off (flame off) (DC ammeter, $R_i \leq 5 k\Omega$)	$\leq 1.6 \mu A$
Detector current required for reliable operation	$\geq 3 \mu A$
Possible detector current during operation	Max. 40 μA
Short-circuit current across terminals 1 and 2 or ground (AC ammeter, $R_i \leq 5 k\Omega$)	Max. 100 μA

Note



With the same quality of flame, the detector current with the LMG... may be lower than that with the LGB2....

Flame supervision is accomplished by making use of the conductivity and rectifying effect of the flame.

The flame signal amplifier only responds to the DC current component of the flame signal.

A short-circuit between ionization probe and ground causes the burner to initiate lockout.

Technical data (cont'd)

Measuring circuit

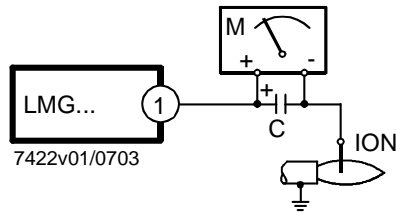

Legend

- C Electrolytic capacitor 100...470 μ F; DC 10...25 V
- ION Ionization probe
- M Microammeter, R_i max. 5,000 Ω

For detector currents, refer to «Technical data».

Flame supervision with AGQ2...A27 and UV detector QRA...

Mains voltage	AC 230 V +10 % / -15 %
Mains frequency	50...60 Hz \pm 6 %
Perm. cable length from QRA... to AGQ2...A27 (lay separate cable)	max. 20 m
Perm. cable length from AGQ2...A27 to LMG...	max. 2 m
Weight of AGQ2...A27	approx. 140 g
Perm. mounting position	optional
Degree of protection	IP 40, to be ensured through mounting
Power consumption	4.5 VA

	At mains voltage U_n	
	AC 220 V	AC 240 V
Detector voltage at QRA... (with no load)		
Until the end of «t10» and after controlled shutdown	DC 400 V	DC 400 V
From the start of «t1»	DC 300 V	DC 300 V
Detector voltage Load by DC measuring instrument $R_i > 10 M\Omega$		
Until the end of «t10» and after controlled shutdown	DC 380 V	DC 380 V
From the start of «t1»	DC 280 V	DC 280 V
DC current detector signals with UV detector QRA...	Min. required	Max. possible
Measurement at the UV detector	200 μ A	500 μ A

Ancillary unit
AGQ2...A27

In connection with burner controls LMG..., use of UV ancillary unit AGQ2...A27 is mandatory.

Using circuitry (A) or (B), the quench test on aging UV detectors can be made in 2 different ways:

1. (A) Operation with a permanent line.
UV test with a higher supply voltage across the UV cell on startup and after the controlled shutdown.
2. (B) Operation with a controlled line.
UV test with a higher supply voltage only on startup during the interval between controlled startup and air pressure signal.
 - No voltage at UV cell after the controlled shutdown
 - No full substitute for mode (A) described above since an aged UV cell can regenerate itself

Connection diagram

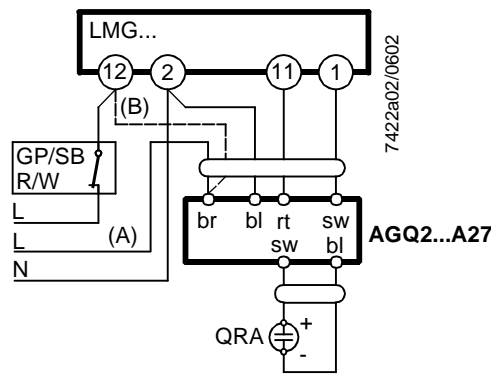

Measuring circuit for measuring the UV detector current

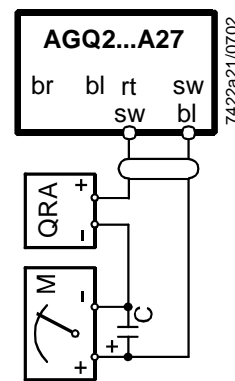

Measurement made at the UV detector

Legend

- C Electrolytic capacitor 100...470 μ F; DC 10...25 V
- M Microammeter Ri max. 5,000 Ω
- QRA... UV detector
- GP Gas pressure switch
- SB Safety limit thermostat
- R Control thermostat or pressurestat
- W Limit thermostat or pressurestat

- bl Blue
- br Brown
- gr Grey
- rt Red
- sw Black

Function

LMG21...

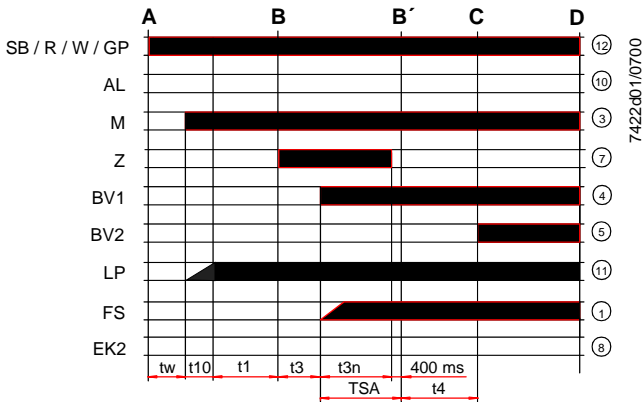

LMG22...

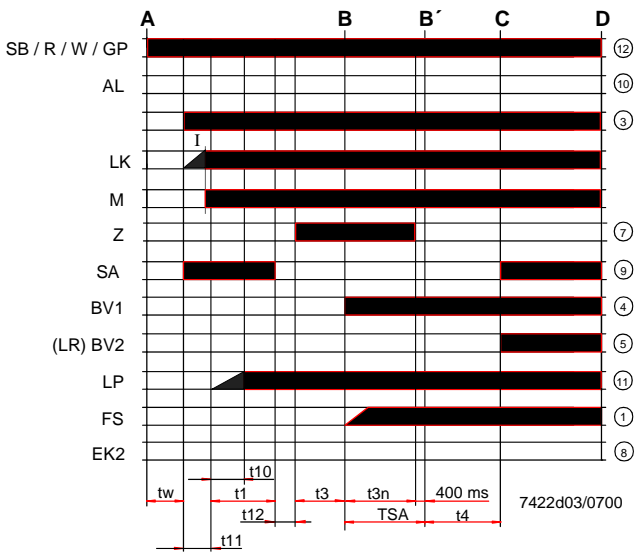

LMG49...

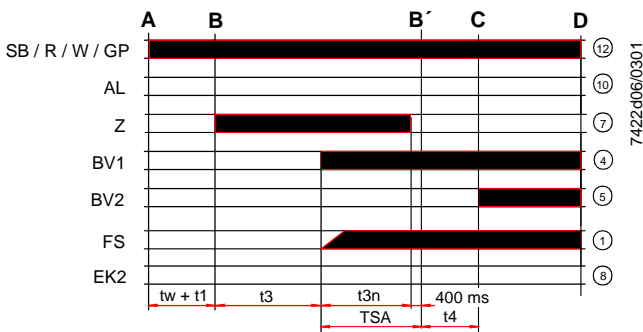

Legend

- A Start command (switching on by «R»)
 - B-B' Interval for establishment of flame
 - C Operating position of burner reached
 - C-D Burner operation (generation of heat)
 - D Controlled shutdown by «R»
 - Burner will immediately be shut down
 - Burner control will immediately be ready for a new startup
-
- AL Error message (alarm)
 - BV... Fuel valve
 - EK2 Remote reset button
 - FS Flame signal
 - GP Gas pressure switch
 - LP Air pressure switch
 - LR Load controller
 - M Fan motor
 - R Control thermostat or pressurestat
 - SA Actuator
 - SB Safety limit thermostat
 - W Limit thermostat or pressure switch
 - Z Ignition transformer
 - I Cam I actuator
-
- t1 Prepurge time
 - t3 Preignition time
 - t3n Postignition time
 - t4 Interval between establishment of flame and release of «BV2»
 - t10 Specified time for air pressure signal
 - t11 Programmed opening time for actuator «SA»
 - t12 Programmed closing time for actuator «SA»
 - TSA Ignition safety time
 - tw Waiting time

Function (cont'd)

Prerequisites for startup	<ul style="list-style-type: none">• Burner control is reset• All contacts in the line are closed• Fan motor «M» or AGK25 is connected• Air pressure switch «LP» is in the normal position• No undervoltage• Fuel valve «BV1» is connected
Undervoltage	<p>Safety shutdown is the event</p> <ul style="list-style-type: none">- mains voltage is lower than AC 180 V (typically)- a restart is made when mains voltage exceeds AC 195 V
Controlled intermittent operation	<p>After no more than 24 hours of continuous operation, the burner control will initiate automatic safety shutdown followed by a restart.</p>
Reversed polarity protection	<p>If the connections of line (terminal 12) and the neutral conductor (terminal 2) have been mixed up, the burner control will initiate lockout at the end of «TSA».</p>
Control program in the event of fault	<ul style="list-style-type: none">• If a fault occurs, all outputs will immediately be deactivated (< 1 second)• On restoration of power, a restart will be made with the full control sequence• If mains voltage drops below the undervoltage threshold (for threshold, refer to «Functions»), a restart will be made with the full control sequence• If there is a premature faulty flame signal during «t1», the burner control will initiate lockout• If the contacts of the air pressure switch «LP» have welded in their working position, startup will be prevented and, after 65 seconds, lockout initiated• If there is no air pressure on completion of «t10», the burner control will initiate lockout• If the burner does not ignite during «TSA», lockout will be initiated• If the flame is lost during operation:<ul style="list-style-type: none">→ LMG21... / LMG22... / LMG49.030B27 lockout→ LMG25... 3 repetitions→ LMG49.031B27 1 repetition
Lockout	<p>Lockout cannot be changed and takes place 10 seconds after safety shutdown. A mains voltage failure during that period a time will lead to a restart.</p>
Resetting the LMG...	<p>Whenever lockout occurs, the burner control can immediately be reset. Press lockout reset button and keep it depressed for 0.5... 3 seconds. The LMG... can be reset only when all contacts in the line are closed and when there is no undervoltage.</p>

Connection diagram

LMG21... / LMG25...

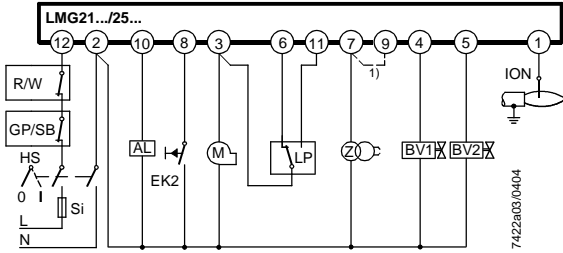

1) Wire link required only with the LGB21..., not with the LMG21... / LMG25...

Application examples

Control of actuators of 2-stage or 2-stage modulating burners.
Controlled pre-purging «t1» with low-fire air volume. Same low-fire actuator position during startup and operation.

For information about actuators «SA»:
SQN3... refer to Data Sheet N7808
SQN7... refer to Data Sheet N7804
SQN9... refer to Data Sheet N7806

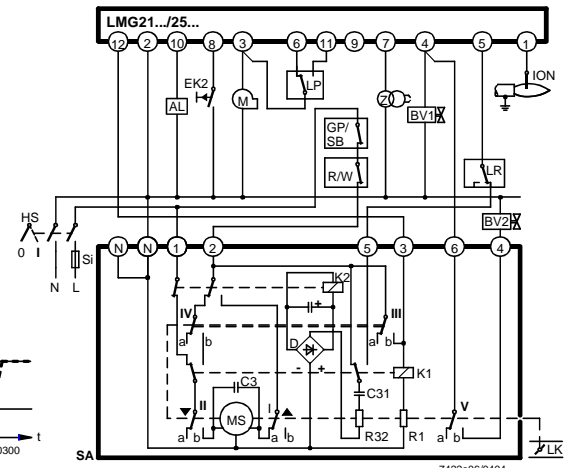
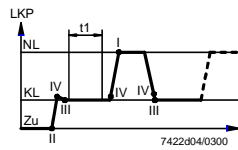
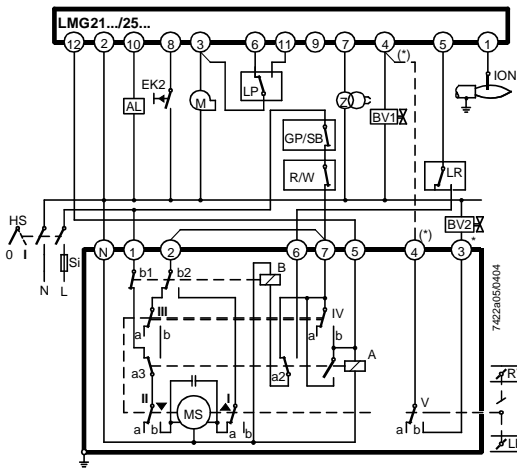
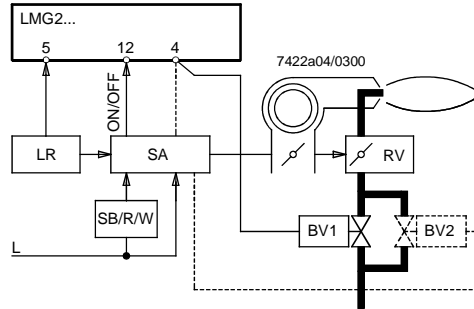

SQN3...121... / 2-stage control

* Note:
With 2-stage modulating burners (with gas regulation damper «RV»), «BV2» and the dotted connection between terminals (*) are not required.

SQN91.140... / 2-stage control

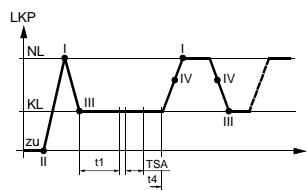
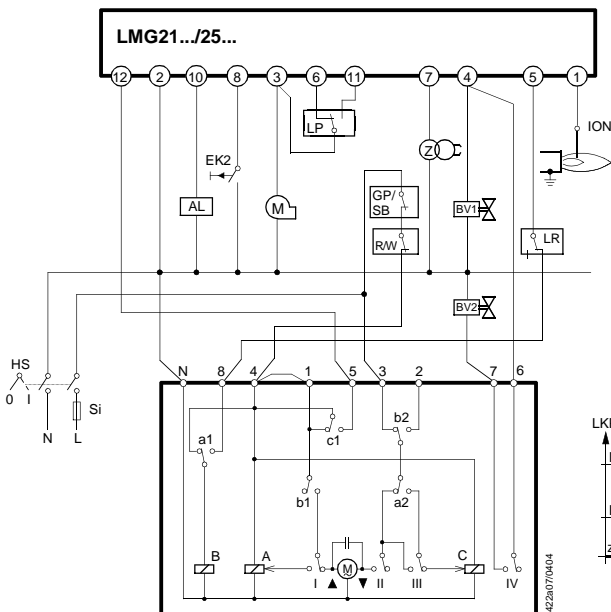

SQN7...244 / 2-stage control

Connection diagram (cont'd)

LMG22...

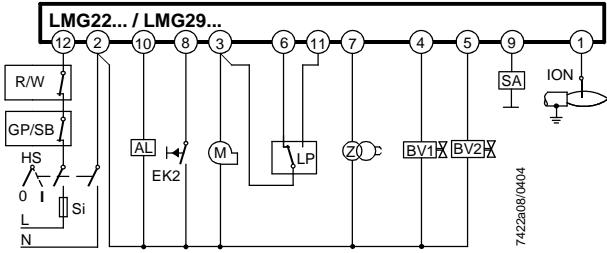

Application examples

Control of actuators of 2-stage or 2-stage modulating burners.
Controlled prepurging «t1» with nominal load air volume.

For information about actuators «SA»:
SQN3... refer to Data Sheet N7808
SQN7... refer to Data Sheet N7804
SQN9... refer to Data Sheet N7806

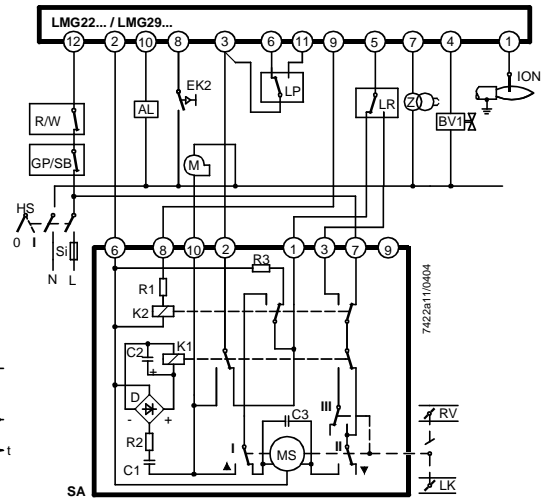
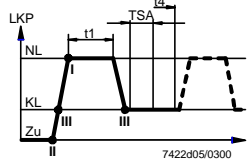
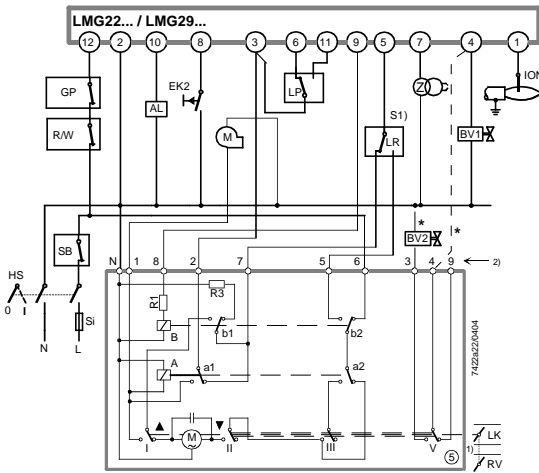
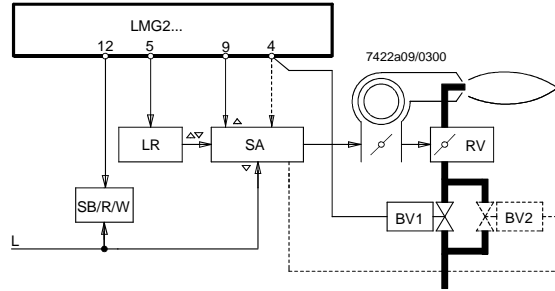

SQN90.220... / 2-stage modulating control

SQN3...151... or SQN3...251...

* Note:

With 2-stage modulating burners (with gas regulation damper «RV»), «BV2» and the dotted connection between terminals (*) are not required.

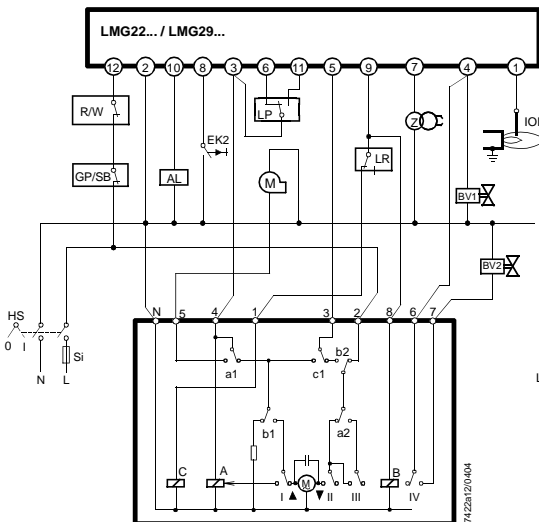

SQN7...454 / 2-stage control, 1-wire control

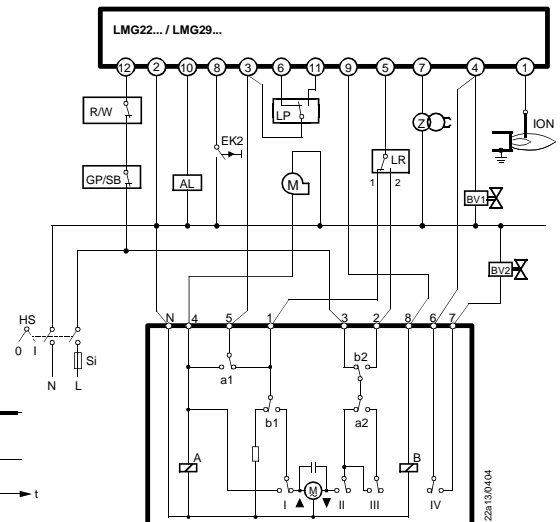
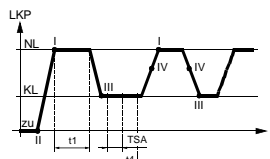

SQN7...424 / 2-stage control, 2-wire control

Connection diagram (cont'd)

LMG49...

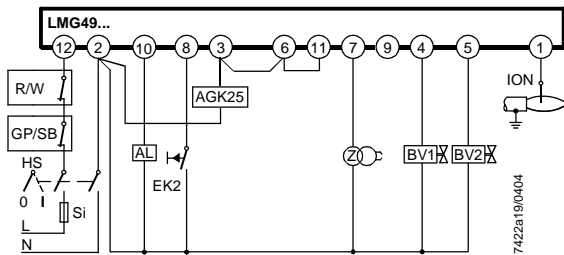

Other application examples

Burner without fan and without «LP»

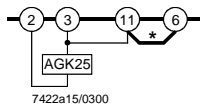

Only for LMG21... / LMG22... / LMG25...

Burner with fan control via auxiliary contactor «HS» with «LP»

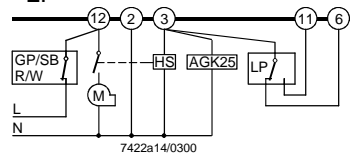

* **Note:** Different from LGB...

Legend

AGK25...	PTC resistor	LR	Load controller
AL	Error message (alarm)	M	Fan motor
BV...	Fuel valve	MS	Synchronous motor
Dbr...	Wire link	NL	Nominal load
EK2	Remote lockout reset button	QRA...	UV detector
ION	Ionization probe	R	Control thermostat / pressurestat
FS	Flame signal	RV	Gas regulation damper
GP	Gas pressure switch	SA	Actuator SQN...
HS	Auxiliary contactor, relay	SB	Safety limit thermostat
K1...4	Internal relays	Si	External fuse
KL	Low-fire	t	Time
LK	Air damper	W	Limit thermostat / pressure switch
LKP	Air damper position	Z	Ignition transformer
LP	Air pressure switch		

Operating concept

<ul style="list-style-type: none"> Burner control has initiated lockout → Red signal lamp illuminated 	<ul style="list-style-type: none"> Reset Press lockout reset button for 0.5...3 s Diagnostics of cause of fault <ul style="list-style-type: none"> Wait > 10 s Press lockout reset button for > 3 s Read blink code of red signal lamp → «Error code table»
<ul style="list-style-type: none"> Burner control in operation → Green flame signal lamp illuminated 	<ul style="list-style-type: none"> Restart Press lockout reset button for 0.5...3 s

Diagnostics of cause of fault

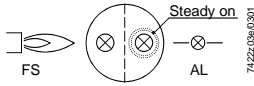

After lockout, the red signal lamp is steady on.
 For reading the cause of fault, refer to the blink code given in the following table:

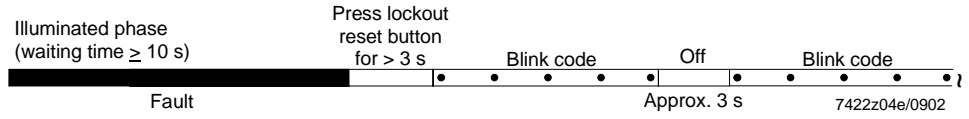

Blink code	Possible cause
2 blinks • •	<ul style="list-style-type: none"> No establishment of flame at the end of «TSA» <ul style="list-style-type: none"> - Faulty or soiled ionization probe - Faulty or soiled fuel valves - Poor adjustment of burner
3 blinks • • •	<ul style="list-style-type: none"> Air pressure switch does not close <ul style="list-style-type: none"> - «LP» faulty - «LP» incorrectly adjusted - Fan motor does not run
4 blinks • • • •	<ul style="list-style-type: none"> Air pressure switch does not open or extraneous light on burner startup <ul style="list-style-type: none"> - «LP» faulty - «LP» incorrectly adjusted
5 blinks • • • • •	<ul style="list-style-type: none"> Extraneous light during prepurging <ul style="list-style-type: none"> - Or internal device fault
7 blinks • • • • • • •	<ul style="list-style-type: none"> Loss of flame during operation <ul style="list-style-type: none"> - Poor adjustment of burner - Faulty or soiled fuel valves - Short-circuit between ionization probe and ground
8...17 blinks • • • • • • • • • • • • • • • • • •	<ul style="list-style-type: none"> Free
18 blinks • • • • • • • • • • • • • • • • • •	<ul style="list-style-type: none"> Air pressure switch opens during prepurging or operation <ul style="list-style-type: none"> - «LP» incorrectly adjusted - 4 times loss of flame during operation (LMG25...) - 2 times loss of flame during operation (LMG49.031...)
19 blinks •	<ul style="list-style-type: none"> Faulty output contact <ul style="list-style-type: none"> - Wiring error - External power supply on output terminal
20 blinks •	<ul style="list-style-type: none"> Internal device fault

During the time the cause of fault is diagnosed, the control outputs are deactivated.

- The burner remains shut down
- Exception: Error message «AL» at terminal 10

The burner is switched on only after a reset is made

- Press lockout reset button for 0.5...3 s

Internal diagram

LMG21... / LMG25...

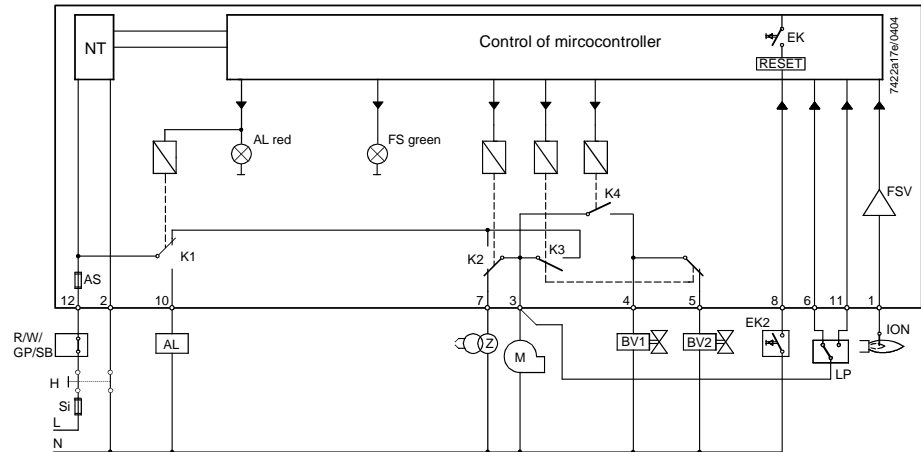

LMG22...

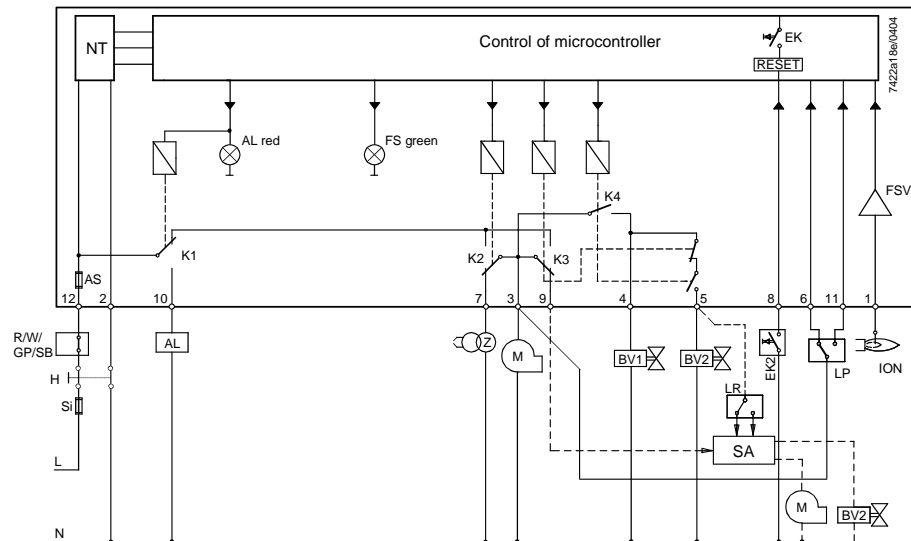

LMG49...

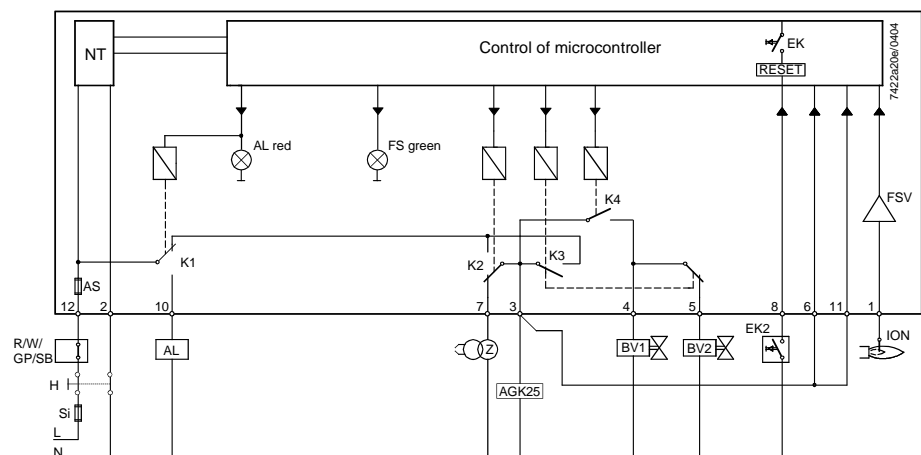

Legend

AL	Alarm	LR	Load controller
AS	Unit fuse	M	Fan motor
BV...	Fuel valve	NT	Power section
EK...	Lockout reset button (built-in)	R	Control thermostat or pressurestat
FS	Flame signal	SA	Actuator
FSV	Flame signal amplifier	SB	Safety limit thermostat
GP	Gas pressure switch	Si	External fuse
H	Main switch	W	Limit thermostat or pressure switch
ION	Ionization probe	Z	Ignition transformer
LP	Air pressure switch		

SIEMENS

Represented By:
POWER EQUIPMENT COMPANY
2011 Williamsburg Road
Richmond, VA 23231
Ph. 804-236-3800
Fx. 804-236-3882
www.peconet.com