

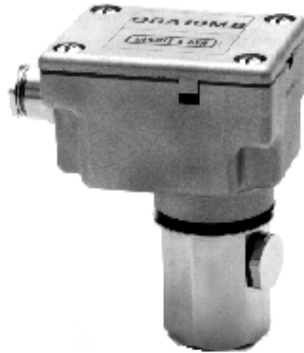

ISO 9001



QRA10...



QRA53..., QRA55... with clamp

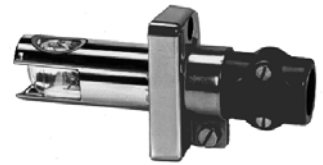

QRA2... with clamp

Flame Detectors

QRA2...
QRA10...
QRA53...
QRA55...

The flame detectors are designed for use with our burner controls, for the supervision of gas and oil flames.

The QRA... and this Data Sheet are intended for use by OEMs which integrate the flame detectors in their products.

Use

The flame detectors are used for the supervision of gas flames, yellow- or blue-burning oil flames and for ignition spark proving.

Type reference	For use with burner control type	Operating mode
QRA2..., QRA10...	LGB2... / LGB4... with AGQ1... LFL... LFE1... LFE10... LMG... with AGQ2...	Intermittent
QRA53..., QRA55...	LGK16... LGI16...	Continuous

Warning notes



To avoid injury to persons, damage to property or the environment, the following warning notes should be observed!

- Before performing any wiring changes in the connection area of the detector, completely isolate the equipment from the mains supply (all-polar disconnection)
- Ensure protection against electric shock hazard by providing adequate protection for the terminals
- Check to ensure that wiring is in an orderly state
- Halogen lamps, welding equipment, special lamps or ignition sparks may produce sufficient radiation for the detector's UV cell to ignite. X-rays and gamma radiation can also generate erroneous flame signals
- Fall or shock can adversely affect the safety functions. Such units may not be put into operation, even if they do not exhibit any damage

Mounting notes

- Ensure that the relevant national safety regulations are complied with
- Mounting work must be carried out by qualified staff

Installation notes

- Installation work must be carried out by qualified staff
- Always run the high voltage ignition cables separate while observing the greatest possible distance to the detector and to other cables

Electrical connection of the flame detector

It is important to achieve practically disturbance- and loss-free signal transmission:

- Never run the detector cable together with other cables
 - Line capacitance reduces the magnitude of the flame signal
 - Use a separate cable
- Observe the permissible lengths of the detector cable (refer to «Technical data»)

Commissioning notes

- Commissioning work must be carried out by qualified staff
- Prior to commissioning, ensure that wiring is in an orderly state
- Trouble-free burner operation is ensured only when the intensity of UV radiation at the detector's location is high enough for the detector's UV cell to ignite during each half wave. The intensity of UV radiation at the detector's location is checked through measurement of the detector current

Measuring circuit for QRA2..., QRA10... and QRA5...of the D-series

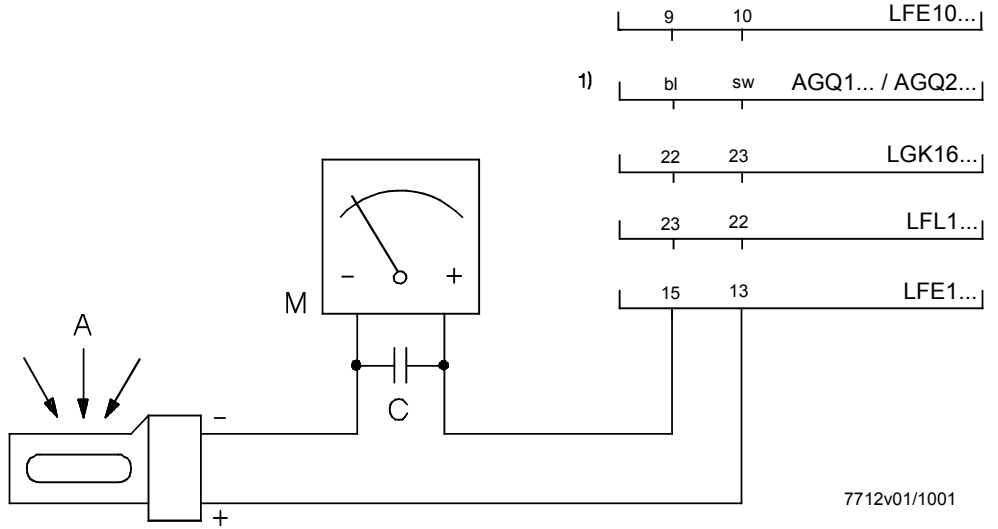

Legend

- 1) Connection of microammeter across adapter AGQ1... / AGQ2... and flame detector
 A Incidence of radiation
 M Microammeter (DC), internal resistance $\leq 5000 \Omega$
 C Electrolytic capacitor 100...470 μF , DC 10...25 V

Measuring circuit for QRA5... up to the C-series

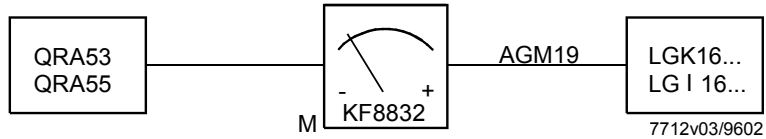

Minimum detector current values required:

Refer to the Data Sheet of the relevant burner control or to the Operating Instructions of the KF8832.

Certificate



Conformity to EEC directives
 - Electromagnetic compatibility EMC (immunity)

89 / 336 EEC



ISO 9001: 2000
 Cert. 00739



ISO 14001: 1996
 Cert. 38233



Valid for all
 QRA...



Valid only for QRA2...
 and QRA10...



Valid for QRA2...

Service notes

- Maintenance work must be carried out by qualified staff
- Each time a unit has been replaced, check to ensure that wiring is in an orderly state
- Use the KF8832 service unit for only short periods of time

Disposal notes



The flame detector contains electrical and electronic components and may not be disposed of together with household waste. Local and currently valid legislation must be observed.

Mechanical design

Flame detectors QRA2...	Plastic housing, metalized to prevent static charging caused by the air flow from the fan. For direct mounting on the burner. The detectors can be supplied with or without securing flange and clamp (refer to «Type summary»).
Flame detectors QRA10...	Die-cast aluminium housing with a 1 in. mounting coupling (D) and a connection facility for cooling air. The housing of this detector has a bayonet fitting which allows it to be secured either directly to the mounting coupling or to the glass holder AGG06. The mounting coupling can be screwed to a viewing tube or to the ball head AGG07. The Pg cable gland can be removed and replaced, if some other detector cable shall be used.
Flame detectors QRA5...	The detector's UV cell is located behind a swiveling shutter at the front end of the detector tube which is flanged to the housing. A quartz glass window protects the tube and the shutter against dirt. The detector's housing accommodates a stepper motor to drive the shutter and the electronics to control the shutter. Using the adapter AGG16.C, this flame detector can be mounted either directly on the burner, on a viewing tube or on a combustion chamber viewing hole.
Plug AGM19	Plug AGM19 complete with cable for the connection of flame detectors QRA53... and QRA55...
Adapter AGG16.C	Adapter AGG16.C for QRA53..., QRA55..., made of die-cast aluminium with a 1 in. mounting coupling. The mounting coupling (D) is attached to the housing with a bayonet fitting.

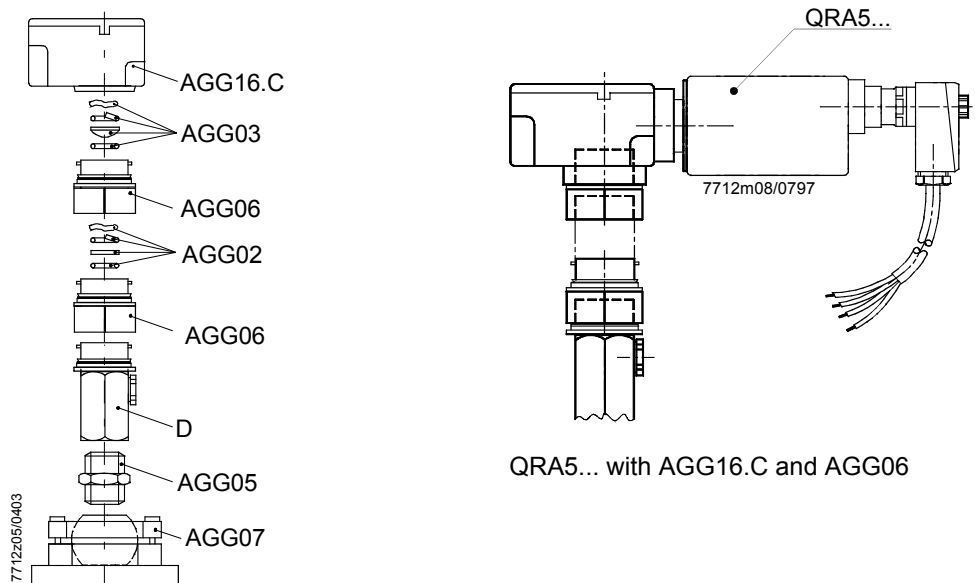

Note AGG03 or AGG02 can also be fitted in the 1 in. mounting coupling (D) of the AGG16.C (or QRA10...). An adapter combination with glass holder AGG06, mounting coupling and ball joint for QRA53..., QRA55... and QRA10... is possible.

Glass and quartz glass lens holder AGG06

The glass and quartz glass lens holder AGG06 serves for holding the lens AGG03 and the heat insulation glass AGG02.

The lens is used to increase the sensitivity, and the heat insulation glass provides protection against high temperatures, thus extending the life of the UV cell.

The AGG06 also allows various combinations of lens, heat insulation glass and 1 in. mounting coupling.

When using the lens and the heat insulation glass, the AGG06 with the lens must be mounted as close as possible to the flame detector.

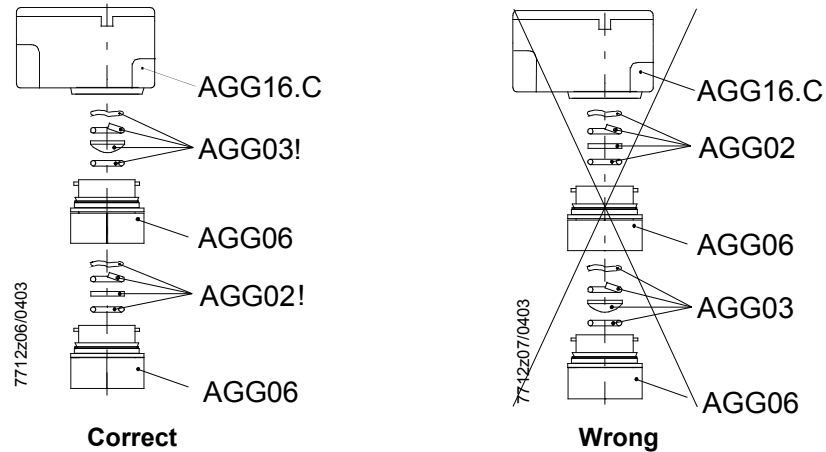

AGG06 has a bayonet fitting with which it is attached either to the housing of adapter AGG16.C or to the housing of flame detector QRA10... and the mounting coupling.

By undoing the bayonet fittings on both sides, the AGG06 glass holder(s) can be easily detached from the combination of QRA10... or AGG16.C and QRA53..., QRA55....

This facilitates straightforward cleaning of the glass or lens without having to remove them from the glass holder AGG06.

The intermediate rings are used for the smooth running of the bayonet fittings, especially where – after removal of the flame detector – the hole to the combustion chamber serves as a viewing tube.

By fitting the intermediate ring to the appropriate bayonet connection, the combination can be undone where required by rotating the housing of the QRA10... or AGG16.C

Quartz glass lens AGG03

AGG03 with spring washer and O-ring for increasing the sensitivity.

Heat insulation glass AGG02

Heat insulation glass AGG02 with spring washer and O-ring, offering the same mounting choices as with the AGG03.

This heat insulation glass is required on applications where the temperature at the flame detector exceeds 80 °C.

Mounting coupling (D)

Using the bayonet fitting, the 1 in. mounting coupling can be attached either to the AGG06, the AGG16.C or the flame detector QRA10....

The mounting coupling is supplied with the QRA10... or AGG16.C.

Nipple AGG05

1 in. nipple AGG05 for connecting the mounting coupling (D) to the ball head AGG07.

Ball head AGG07

Ball head with 1 in. internal thread.

For use with the 1 in. mounting coupling and the AGG06.

The AGG07 is used for mounting on a rigid surface, such as the boiler wall.

It facilitates optimum adjustment of the viewing angle.

Type summary

Flame detectors

Type reference	Sensitivity	Flange and clamp	Terminal cover	Spare UV tube
QRA2	normal	without	black	4 502 1131 0
QRA2(1)		with		
QRA2.9²⁾		without		
QRA2M	high	without	green	4 502 4065 7
QRA2M(1)		with		
QRA10.C	normal	---	---	4 502 1131 0
QRA10M.C	high	---	---	4 502 4065 7

Type reference	Sensitivity	Detector tube length	Mains voltage	Spare UV tube
QRA53.C27	normal	125 mm	AC 220...240 V	4 502 4065 7
QRA53.C17			AC 100...110 V	
QRA53.D27	high		AC 220...240 V	
QRA53.D17			AC 100...110 V	
QRA55.C27	normal	77 mm	AC 220...240 V	
QRA55.C17			AC 100...110 V	
QRA55.D27	high		AC 220...240 V	
QRA55.D17			AC 100...110 V	

Note

All QRA5... are delivered complete with clamp. Use of the detector requires a connecting cable **AGM19** (refer to «Accessories» for QRA5...).

Accessories for QRA2... and QRA5... when ordered as single items

Part	For use with	Part number
Flange ³⁾ rounded	QRA2...	4 241 8855 0
Flange straight	QRA2...	4 241 8898 0
Clamp ³⁾	QRA2...	4 199 8806 0
Clamp for direct mounting ⁴⁾	QRA5...	4 199 1034 0

Accessories for QRA5...

Type reference	Description
AGG16.C	Adapter for QRA53... and QRA55...
AGM19	Plug complete with 2 m cable for QRA53... and QRA55...
KF8832	Unit for measuring the detector current with QRA53... and QRA55..., recommended for use with detector types up to the C-series

Accessories for QRA10... and AGG16.C

Type reference	Description
AGG02	Heat insulation glass with spring washer and O-ring
AGG03¹⁾	Quartz glass lens with spring washer and O-ring
AGG05	1 in. nipple
AGG06	Glass and quartz glass lens holder with intermediate ring
AGG07	Ball head with 1 in. internal thread

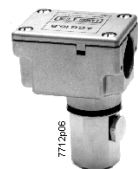

AGG16.C



KF8832



AGM19



AGG05



AGG06 with intermediate ring



AGG07

Legend

- 1) For detectors of the B-series, lens AGG01 is available
- 2) With heat-resistant housing for ambient temperatures up to 200 °C (short-time, up to a few seconds)
- 3) Supplied with QRA2...(1) types
- 4) Supplied with QRA5... types

Ordering

When ordering, please give type references according to «Type summary».

Technical data

General detector data	Average life of UV cell	approx. 10,000 hours at max. 50 °C, higher ambient temperatures reduce considerably the cell's life
	Perm. combustion chamber pressure	
	- QRA10...	max. 50 mbar
	- QRA10... + AGG03 or AGG02	max. 500 mbar
	Degree of protection	
	- QRA2...	IP 40
	- QRA10...	IP 54
	- QRA53..., QRA55...	IP 54
	Mounting position	optional
	Weight	
	- AGG01	approx. 10 g
	- AGG02	approx. 10 g
	- AGG03	approx. 10 g
	- AGG05	approx. 170 g
- AGG06	approx. 160 g	
- AGG07	approx. 1330 g	
- AGG16.C	approx. 650 g	
- QRA2...	approx. 60 g	
- QRA10...	approx. 740 g	
- QRA10... + AGG03	approx. 750 g	
- QRA53..., QRA55...	approx. 900 g	
Ignition cable (only QRA2...)	2 x 0.75 mm ² ; 5.1 mm dia.	
Environmental conditions	Transport	DIN EN 60 721-3-2
	Climatic conditions	class 2K2
	Mechanical conditions	class 2M2
	Temperature range	-20...+60 °C
	Humidity	< 95 % r.h.
	Operation	DIN EN 60 721-3-3
	Climatic conditions	class 3K5
	Mechanical conditions	class 3M2
	Temperature range	-20...+60 °C
	Humidity	< 95 % r.h.
Condensation, formation of ice and ingress of water are not permitted!		

Function

With this type of flame supervision, the UV radiation emitted by gas or oil flames is used to generate the flame signal.

The radiation detector consists of a UV-sensitive cell with 2 electrodes, which ignite when illuminated with radiation in the 190...270 nm range of the spectrum, thereby triggering a current in the flame detector circuit.

The UV cell does not respond to glowing firebrick in the combustion chamber, daylight or light from the boiler room illumination.

Dimensions

Dimensions in mm

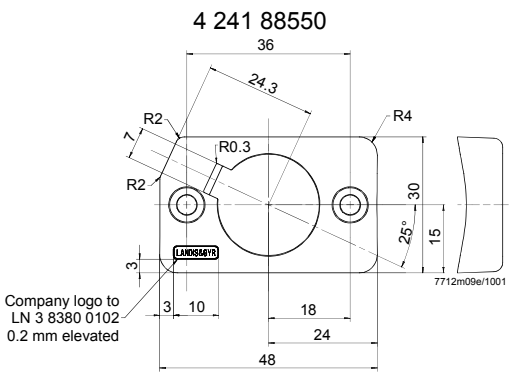
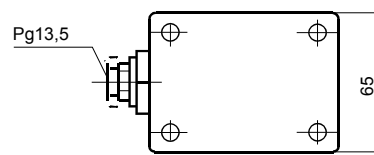
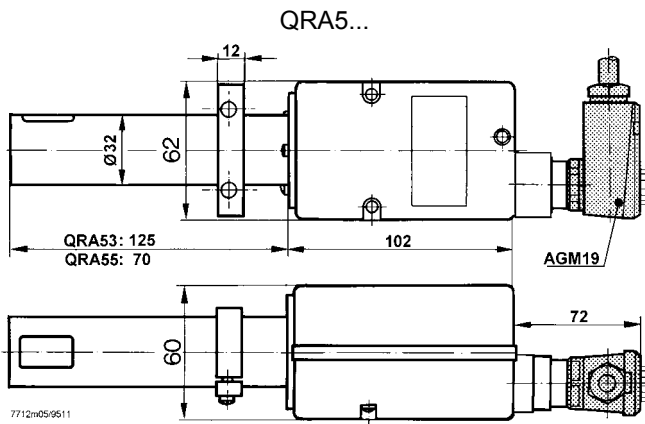
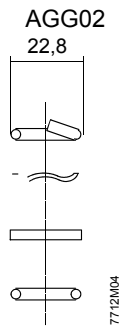
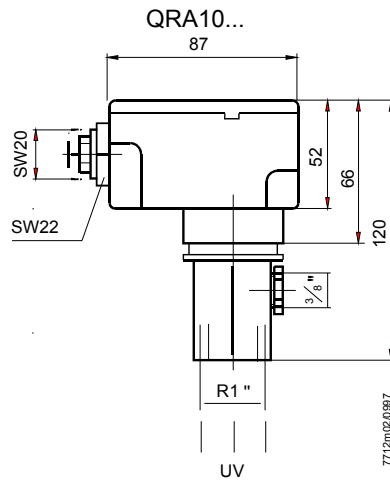
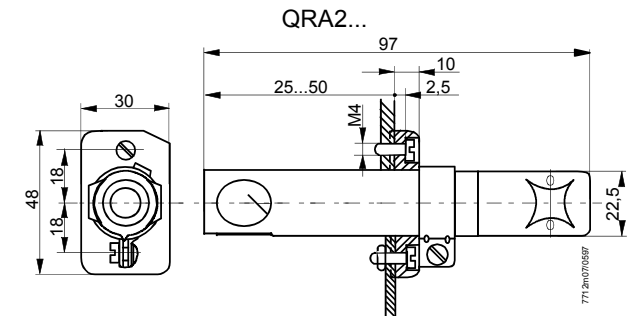

QRA5... with AGG05, AGG06, AGG07, AGG16.C and AGM19

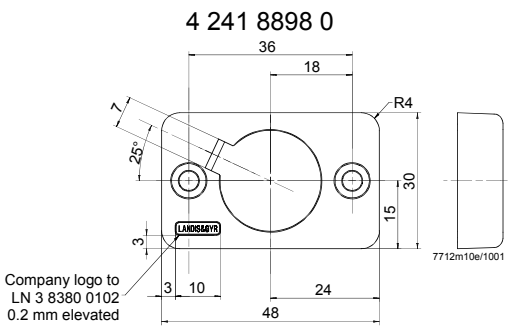
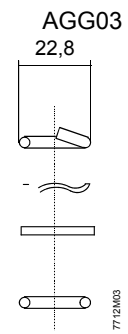
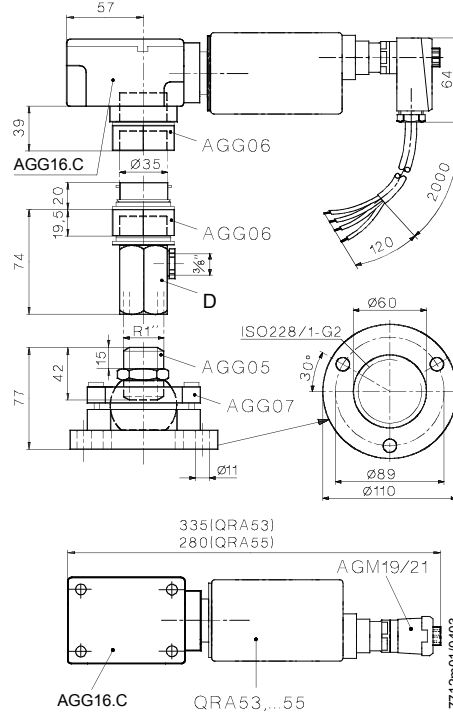

Incidence of radiation

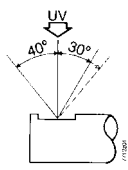

Clamp for direct mounting on the burner or the AGG16.C

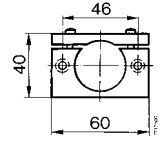

SIEMENS

Represented By:
POWER EQUIPMENT COMPANY
2011 Williamsburg Road
Richmond, VA 23231
Ph. 804-236-3800
Fx. 804-236-3882
www.peconet.com